

aiwa[®]

HOUSEHOLD APPLIANCES 2024

aiwa[®]
Japan est1951

Welcome to AIWA, an emblematic brand from Japan, synonymous with quality, tradition, and technological heritage since 1951. Our mission, under the mandate of Sony Corporation, is to lead as the flagship in home appliances, bringing excellence and innovation to every home. At AIWA, we merge Japanese precision with technological forefront to create products that not only enrich everyday life but also continue a legacy of superiority and trust.

Every AIWA product reflects our commitment to perfection, attention to detail, and customer satisfaction, establishing us as a premium brand in the global market. We pride ourselves on being carriers of Japanese excellence, dedicated to exceeding expectations and paving the way to the future of home appliance technology. With AIWA, discover an experience where tradition meets innovation to deliver unparalleled quality.

Welcome to the future, welcome to AIWA.

OUR HISTORY

Welcome to AIWA, an emblematic brand from Japan, synonymous with quality, tradition, and technological heritage since 1951.

THE GENESIS OF EXCELLENCE

In the bustling heart of Tokyo, AIWA was born, a beacon of innovation destined to revolutionize audio technology. From day one, our commitment to quality set us on a path to lead and redefine the industry.

1951



TRAILBLAZING AUDIO INNOVATION

AIWA introduces Japan's first domestically produced reel-to-reel tape recorder, marking the dawn of a new era in high-fidelity sound. Our pioneering spirit cements our reputation as architects of exceptional audio experiences

1960



Our Horizon

AIWA is at the forefront of innovation, dedicated to quality and excellence. As the flagship brand for home appliance development, we push technological boundaries to enhance everyday life.

Expanding into smart home devices and beyond, we leverage advanced technology and strategic insights to create intuitive and indispensable products. Our commitment to innovation and user experience is setting new industry standards.

Looking ahead, our goal is to become a global household name, synonymous with quality and trust. We aim to enrich consumers' lives with exceptional products, ensuring AIWA remains a beacon of excellence for generations to come.

2020

PIONEERING THE HOME APPLIANCES SECTOR

AIWA's expansion into home appliances marks a significant evolution. Our mission to lead in innovation and quality is now broader, touching every corner of the home with AIWA's signature excellence.



2002

A STRATEGIC ALLIANCE WITH SONY

The acquisition by Sony Corporation wasn't just a milestone; it was a testament to AIWA's value and potential. Together, we embarked on a journey of synergistic innovation, backed by Sony's belief in AIWA's legacy and future.



1990

DIVERSE INNOVATION

Our expansion into video, car audio, and multimedia solutions wasn't just growth—it was a declaration. AIWA was more than an audio company; we were a lifestyle brand, enhancing every aspect of our consumers' lives.

1970

Unleashing Music Mobility

With the launch of portable cassette players, AIWA didn't just follow trends—we set them. We transformed music into a companion that traveled with you, anywhere, anytime, solidifying our role as innovators of music on the move.



1980

THE DIGITAL REVOLUTION

As the digital age dawned, AIWA was at the forefront, embracing the future with our cutting-edge CD players and stereo systems. Our global acclaim was not just for the technology we created but for the experiences we made possible.



INDEX



KITCHEN SOLUTIONS

FOOD PREPARATION

Hand blenders.....	10
Table blenders.....	18
Personal blenders.....	24
Choppers.....	28
Hand mixers.....	29

BREAKFAST

Toasters.....	32
Sandwich & grill.....	36
Kettles.....	38
Citrus juicers.....	43

FOOD COOKING

Air fryers.....	48
Multi-Cooker.....	56
Microwaves.....	58



HOME CARE

WET & DRY	64
VACUUM CLEANERS	68
SPOT CLEANERS	78
MATRESS CLEANERS	82

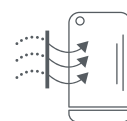

AIR TREATMENT

PORTABLE AIRS	86
PURIFIERS	88
DESHUMIDIFIERS	90
AIR ACONDITIONING	
Haruair Serie	92
Fujinair Serie	98
Sujinair Serie	104

SOLK



KITCHEN SOLUTIONS



Discover Aiwa's commitment to minimalist design and precise Japanese engineering in our Food Preparation range. High-quality, user-centric appliances streamline your kitchen experience, embodying the seamless fusion of simplicity and sophistication to elevate everyday life.

KENKIRI SERIES

CRAFTED WITH PRECISION, OUR AIWA KENKIRI BLENDERS REFLECT THE ZENITH OF JAPANESE ENGINEERING & QUALITY HIGH STANDARDS.

Experience the zenith of blending technology with Aiwa's Kenkiri series, where potent performance, superior materials, and meticulous Japanese craftsmanship converge to redefine kitchen convenience.

Potent Performance: At the heart of each Kenkiri blender lies a robust motor, ranging from 600W to a formidable 2000W, designed for both endurance and efficiency. The power spectrum across the series ensures a match for every culinary challenge, from light mixtures to dense ingredients.

Exquisite Material Quality: Precision-engineered with premium-grade stainless steel, the Satoku® Kenkiri series boasts unparalleled durability. The motors, forged for longevity, and the titanium razor-sharp blades, honed for precision cutting, stand testament to the blend of technology and toughness.

Sophisticated Design: The Kenkiri line embodies sleek aesthetics with ergonomic considerations, presenting a range of hand blenders that are as pleasing to the eye as they are comfortable in the grip. The seamless integration of components assures ease of use, coupled with a clean, modern silhouette that complements any kitchen decor.

Japanese Control of Quality: Adhering to strict Japanese quality standards, each Kenkiri blender undergoes rigorous testing to guarantee reliability. This unwavering attention to detail ensures that every product not only meets but exceeds the expectations set by culinary enthusiasts.



HAND BLENDER
KITCHEN SOLUTIONS



Power	1500 W
Speed control	40 + Turbo
Blades type	6 Titanium Satoku®
Rod	Stainless Steel
Accessories	3
BPA Free	

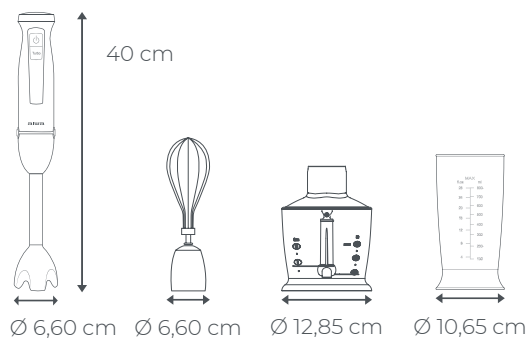

KENKIRI 1500 PLUS

HAND BLENDER ABL-1500 PLUS

- **Power:** 1500W motor, delivering professional performance.
- **Speed Settings:** 40 variable speeds plus a Turbo function for customized blending.
- **Blades:** 6 Titanium Satoku® blades designed for efficiency and durability.
- **Accessories:** Comes with an 800 ml measuring cup with lid, a 500 ml chopper, and a stainless steel whisk.
- **Versatility:** Enhanced with additional accessories for a comprehensive blending experience.
- **Rod:** Stainless steel construction for consistent, high-quality blending. **Antisplash proof.**

POWER AND VERSATILITY IN ONE DEVICE

Versatile Toolkit: Enhanced with a chopper and whisk alongside the powerful motor, the 1500+ model is the ultimate kitchen multitasker.

Expertly Equipped: The inclusion of durable, precision-engineered titanium blades and diverse accessories makes it a powerhouse for any culinary creation.

Effortless Control: With extensive speed settings and a Turbo boost, this model offers complete control over texture and consistency.



1500W	40 Speed Control	Splash-Proof	22.5 cm Stainless steel foot	3 Accessories	TURBO Function
BPA Free	6 Satoku® Blades	Titanium			

MODEL: ABL-1500 PLUS		
PRODUCT CODE	BAR CODE	MASTER BOX
9181002	8435256810127	8

HAND BLENDER

KITCHEN SOLUTIONS



Power	1500 W
Speed control	40 + Turbo
Blades type	6 Titanium Satoku®
Rod	Stainless Steel
Accessories	1
BPA Free	

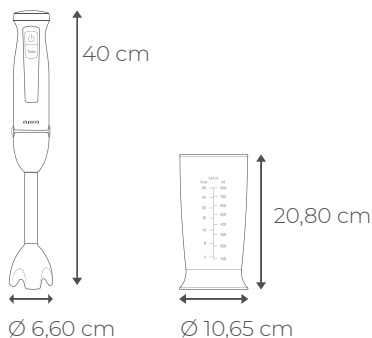

KENKIRI 1500

HAND BLENDER ABL-1500

- **Power:** 1500W motor for high-powered blending tasks.
- **Speed Settings:** 40 speed options plus a Turbo feature for precise control.
- **Blades:** 6 Titanium Satoku® blades for superior cutting and longevity.
- **Accessories:** Includes an 800 ml measuring cup with lid for accurate ingredient portions.
- **Construction:** Durable stainless steel (SS) rod for long-lasting use.
- **Design:** Professional build quality suitable for both home and commercial kitchens. **Antisplash proof.**

ULTIMATE PRECISION AND POWER FOR EVERY BLEND

Powerful Precision: With a robust 1500W motor and 40 speed settings plus Turbo, the KENKIRI 1500 delivers unmatched precision for any blending task.

Titanium Edge: The six titanium blades Satoku® ensure long-lasting sharpness and superior performance in cutting through tough ingredients.

Quality Build: The durable stainless steel rod is crafted for longevity, reflecting the blender's high-quality construction.



1500W	40 Speed Control	Splash-Proof	22.5 cm Stainless steel foot	1 Accessories	TURBO Function
BPA Free	6 Satoku® Blades	Titanium			

MODEL: ABL-1500		
PRODUCT CODE	BAR CODE	MASTER BOX
9181001	8435256810110	6

HAND BLENDER
KITCHEN SOLUTIONS



Power	1200 W
Speed control	40 + Turbo
Blades type	6 Titanium Satoku®
Rod	Stainless Steel
Accessories	4
BPA Free	

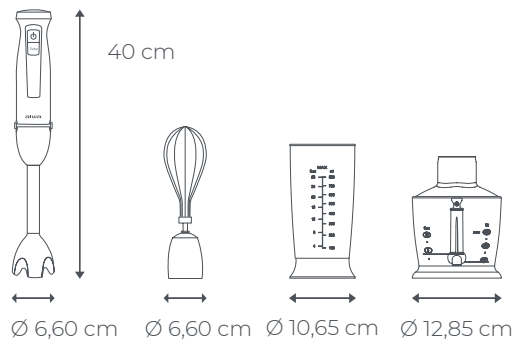

KENKIRI 1200 PLUS

HAND BLENDER ABL-1200 PLUS

- **Power:** 1200W for robust blending capabilities.
- **Speed Settings:** Offers 40 speeds plus a Turbo option for adaptable blending.
- **Blades:** Equipped with 6 Titanium Satoku® blades for exceptional blending.
- **Accessories:** Not only an 800 ml measuring cup with lid but also a 500 ml chopper and a stainless steel whisk.
- **Functionality:** Tailored for the enthusiast looking for more than just blending.
- **Rod:** Durable stainless steel construction for lasting use. **Antisplash proof.**

PRECISION BLENDING POWER WITH FLEXIBLE FUNCTIONALITY

Comprehensive Capability: Comes with additional accessories for chopping and whisking, making it a versatile addition to any kitchen.

High-Performance Blades: Six titanium blades Satoku® offer consistent and precise blending for a range of recipes.

Customizable Speed: Numerous speed options plus Turbo mean you can tackle a wide variety of blending tasks with ease.



1200W	40 Speed Control	Splash-Proof	22.5 cm Stainless steel foot	3 Accessories	TURBO Function
BPA Free	Titanium	6 Satoku® Blades			

MODEL: ABL-1200 PLUS		
PRODUCT CODE	BAR CODE	MASTER BOX
9181006	8435256810103	8

HAND BLENDER

KITCHEN SOLUTIONS



Power	1200 W
Speed control	40 + Turbo
Blades type	6 Titanium Satoku®
Rod	Stainless Steel
Accessories	Baker with lid
BPA Free	

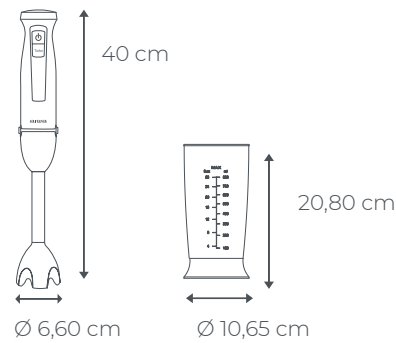

KENKIRI 1200

HAND BLENDER ABL-1200

- **Power:** 1200W motor, balancing power and energy efficiency.
- **Speed Settings:** 40 speeds plus Turbo, catering to a range of textures.
- **Blades:** 6 Titanium Satoku® blades for sustained sharpness and performance.
- **Accessories:** Includes an 800 ml measuring cup with lid.
- **Design:** Streamlined and robust, with a focus on performance.
- **Rod:** Stainless steel rod designed to withstand daily use. **Antisplash proof.**

POWER AND PERFORMANCE IN EVERY BLEND

Balanced Power: The 1200W motor provides a perfect blend of energy efficiency and blending power for everyday kitchen tasks.

Tailored Textures: Multiple speed settings and Turbo give users the ability to achieve the desired consistency every time.

Functional Design: A focus on straightforward functionality, this model combines professional blending capability with ease of use.



1200W	40 Speed Control	Splash-Proof	22.5 cm Stainless steel foot	1 Accessories	TURBO Function
BPA Free	Titanium	6 Satoku® Blades			

MODEL: ABL-1200		
PRODUCT CODE	BAR CODE	MASTER BOX
9181005	8435256810097	6

HAND BLENDER
KITCHEN SOLUTIONS



Power	500W (Max. 600W)
Speed control	2 + Turbo
Blades type	Double action cut
Accessories	4
Rod	Stainless Steel
BPA Free	

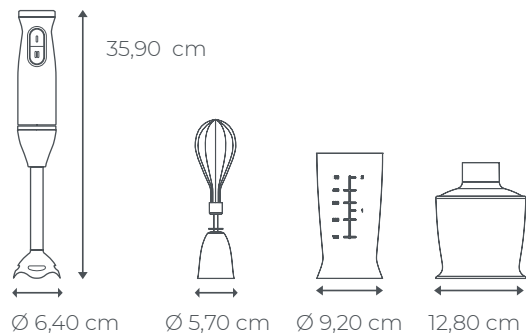

KENKIRI 800PLUS

HAND BLENDER ABL-800 PLUS

- **Power:** 600W motor perfect for everyday blending tasks.
- **Speed Settings:** Two speeds plus Turbo for quick and easy blending.
- **Blades:** Kenkiry sword blades tailored for all basic blending requirements.
- **Accessories:** Includes a 500 ml measuring cup with lid and a 500 ml chopper plus a stainless steel whisk.
- **Enhanced:** Additional accessories for greater versatility.
- **Rod:** Stainless steel rod for consistent blending and stability. **Antisplash proof.**

ELEVATING EVERYDAY BLENDING WITH ENHANCED VERSATILITY

Enhanced Versatility: This model steps up with a chopper and whisk, elevating it to a multi-use tool that's still compact and easy to store.

Simple Speed Selection: With intuitive speed settings, it's designed for ease and simplicity, perfect for quick culinary tasks.

Reliable Performance: The Kenkiry sword blades and sturdy design ensure long-term reliability for daily blending routines.



MAX 600W
2 Speed Control
Splash-Proof
20 cm Stainless steel foot
3 Accessories
TURBO Function

BPA Free

MODEL: ABL-800 PLUS		
PRODUCT CODE	BAR CODE	MASTER BOX
9181004	8435256810141	6

HAND BLENDER

KITCHEN SOLUTIONS



Power	500W (Max. 600W)
Speed control	2 + Turbo
Blades type	Double action cut
Accessories	500 ml measuring cup and lid
Rod	Stainless Steel
BPA Free	

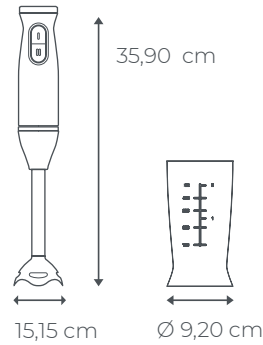

KENKIRI 800

HAND BLENDER ABL-800

- **Power:** An 600W motor suitable for standard blending needs.
- **Speed Settings:** Two speed settings plus Turbo for simple operation.
- **Blades:** Kenkiry sword blades for effective blending.
- **Accessories:** Comes with a 500 ml measuring cup with lid.
- **Compact:** Ideal for smaller kitchens or less frequent use.
- **Rod:** Made with stainless steel, ensuring quality and durability. **Antisplash proof.**

EFFORTLESS BLENDING FOR EVERYDAY TASKS

Compact Efficiency: The 800 model's motor is ideal for quick, everyday blends and perfect for small kitchen spaces.

Essential Accessories: With a 500 ml measuring cup included, this model is ready for straightforward blending right out of the box.

Durable Construction: The stainless steel rod promises durability for consistent use over time.



MAX 600W	2 Speed Control	Splash-Proof	20 cm Stainless steel foot	1 Accessories	TURBO Function
BPA Free					

MODEL: ABL-800		
PRODUCT CODE	BAR CODE	MASTER BOX
9181003	8435256810134	6

SABERU SERIES

ENGINEERED WITH PRECISION HARNESSING THE PINNACLE OF AIWA'S DEDICATION TO EXCELLENCE, THE SABERU BLENDERS EPITOMIZE JAPANESE ENGINEERING AND QUALITY, A SERIES WHERE CUTTING-EDGE TECHNOLOGY MEETS MINIMALIST DESIGN.

Elevate your blending with the SABERU series by Aiwa, where innovative design, patented precision, and superior Japanese craftsmanship unite to transform your kitchen experience

Variable Power for Any Task: From the 550W personal blender to the mighty 2500W table blender, the SABERU series offers a range of power options to suit every preparation need with the ease and efficiency Aiwa is known for.

Premium Material Construction: The SABERU blenders are built with the highest quality materials, from the BPA-free Tritan® jars that guarantee safety and durability to the high-resistance glass options, ensuring a product that lasts.

SATOKU Blade Excellence: With Aiwa's patented Satoku® blades, these blenders deliver unparalleled cutting precision, giving you consistently fine results and a smooth blend, regardless of the ingredients.

Intuitive Controls: Simplify your blending with user-friendly programmes, from a single setting for straightforward tasks to multiple options and pulse controls for complex recipes.

Japanese Aesthetics and Durability: Each SABERU blender is a masterpiece of minimalist design, blending effortlessly into any kitchen environment with the promise of enduring performance.

Quality Without Compromise: True to Aiwa's legacy, the SABERU series is subjected to rigorous quality checks, ensuring every appliance exceeds the high expectations synonymous with Japanese-made products.



TABLE BLENDER
KITCHEN SOLUTIONS



Power	1500 W
Volume Jar	2 L
Programme	4 + Pulse
Speed control	Yes
Jar material	Tritan®
Blades Satoku® Patented	6
Autoclean	Yes

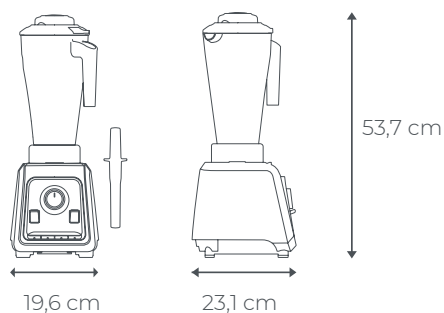

SABERU PRO
TABLE BLENDER ATB-3000

- **1500W Power:** Balances efficiency and strength for professional environments.
- **2L TRITAN Jar:** Large and robust, ideal for heavy use without compromising on quality.
- **Four Programmes + Pulse:** Offers versatility for a wide array of blending techniques.
- **Six Satoku® Blades:** Ensures unparalleled precision and longevity.
- **Ergonomic and Safe Design:** Designed for frequent use with user safety in mind.
- **Noise Reduction Technology:** Engineered for quieter operation in professional settings.

USER-CENTRIC DESIGN: SABERU PRO

Substantial and Sturdy Jar: Equipped with a 2-liter TRITAN jar, this blender is designed to handle heavy usage without sacrificing quality, ensuring durability and reliability in fast-paced settings.

Versatile Blending Options: With four distinct programs plus a pulse feature, the SABERU PRO can effortlessly adapt to a broad range of blending techniques, from delicate mixes to robust purees.

Advanced Blade System: The six Satoku® Blades are designed not only for their precision cutting ability but also for their lasting sharpness, providing consistent results and enduring performance.

Quiet Operation: Innovative noise reduction technology minimizes sound output, a crucial feature for maintaining a more pleasant and professional atmosphere in open-kitchen layouts and small spaces.



1500W	2L	4 Presets	PULSE switch	6 Satoku® Blades	Autoclean
TRITAN® Jar	BPA Free	Anti fingerprint			

MODEL: ATB-3000		
PRODUCT CODE	BAR CODE	MASTER BOX
9182004	8435256810455	2

TABLE BLENDER
KITCHEN SOLUTIONS



Power	2500W max
Volume Jar	1,5 L
Programme	6
Jar material	Glass
Speed control	Yes
Blades Satoku® Patented	6
Autoclean	Yes

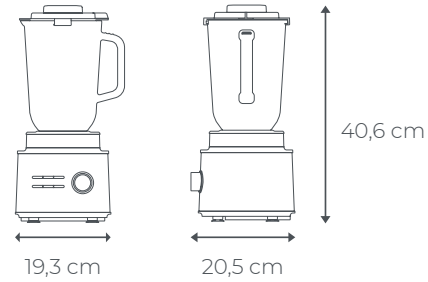

SABERU 2500

TABLE BLENDER ATB-2500

- **2500W Power:** The ultimate in blending power for commercial-grade performance.
- **1.5L Glass Jar:** Extra-large capacity for bulk preparations.
- **Six Programmes:** Comprehensive settings for any blending need, from smooth purees to crushed ice.
- **Six Satoku® Blades:** Delivers exceptional cutting performance.
- **Professional Durability:** Built to last, even under intense use.
- **Precision Control:** Tailored for the precise execution of complex recipes.

SABERU 2500: UNLEASH CULINARY EXCELLENCE WITH UNRIVALED POWER AND PRECISION

Peak Power: With a 2500W motor, the SABERU 2500 offers unparalleled blending power, ideal for commercial environments and the most demanding kitchen tasks.

Maximum Capacity: A 1.5-liter glass jar provides ample space for large-scale recipes, ensuring efficiency in high-volume settings.

Versatile Functionality: Featuring six versatile programs — smoothie, ice cream, auto-clean, ice-crush (perfect for crushing ice), vegetable & fruit function, and puree function — this blender excels at creating everything from finely pureed soups to perfectly crushed ice.

Superior Blade Technology: The six Satoku® Blades are precision-engineered for outstanding performance, delivering consistently smooth cuts and long-term durability.

Built for Professionals: The SABERU 2500 is designed with professional durability in mind, capable of withstanding rigorous and frequent use without compromising on performance.

Control and Consistency: Precision control is at your fingertips, allowing for the meticulous execution of complex recipes to meet the highest culinary standards.



MODEL: ATB-2500		
PRODUCT CODE	BAR CODE	MASTER BOX
9182003	8435256810448	4

TABLE BLENDER
KITCHEN SOLUTIONS



Power	1800 W
Volume Jar	1,8 L
Programme	2 + Pulse + Variable
Speed control	Yes
Jar material	Glass
Blades Satoku® Patented	6

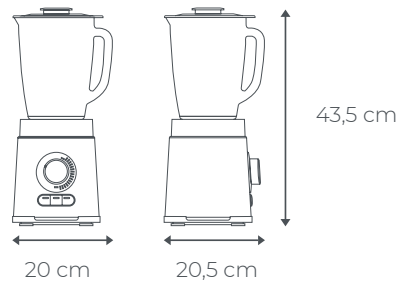

SABERU 1800

TABLE BLENDER ATB-1800

- **1800W Power:** Superior power output for professional-grade blending.
- **1.8L Glass Jar:** Ample capacity matched with the purity and clarity of glass.
- **Two Programs + Pulse+ Variable:** Enhanced control for fine-tuning texture and consistency. Ice Crush + Autoclean + Pulse + Variable program.
- **Six Satoku® Blades:** Precision cutting for even the most challenging ingredients.
- **Intuitive Interface:** User-friendly speed controls for ease of use.
- **Advanced Safety Features:** Ensures safe operation with every use.

ELEVATE YOUR BLENDING EXPERIENCE

Unmatched Blending Power: The 1800W motor of the SABERU 1800 is engineered for superior performance, providing professional-grade power that makes blending smooth, fast, and effortless.

Spacious Glass Jar: The large 1.8-liter glass jar offers not only the space needed for larger recipes but also the purity and clarity of glass to ensure that your blends are clean and contaminant-free.

Customizable Blending Experience: With three specialized programs plus a pulse option, this blender caters to all your blending needs, allowing for perfect texture and consistency adjustments.

Cutting-Edge Blades: Equipped with six Satoku® Blades, the SABERU 1800 guarantees precision cutting, smoothly handling a diverse range of ingredients from soft fruits to hard nuts.

Ease of Use: The intuitive interface is designed for straightforward use, making it accessible to users of all skill levels.



MODEL: ATB-1800		
PRODUCT CODE	BAR CODE	MASTER BOX
9182001	8435256810431	4

TABLE BLENDER
KITCHEN SOLUTIONS



Power	1500 W
Volume Jar	1,5 L
Programme	2 + Pulse
Jar material	Glass
Blades Satoku® Patented	6

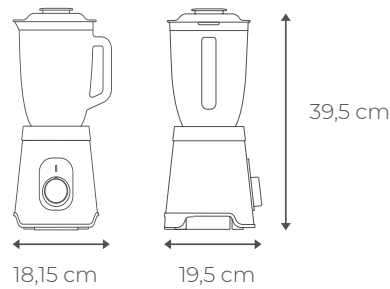

SABERU 1500

TABLE BLENDER ATB-1500

- **1500W Power:** High-performance motor for tackling tough ingredients with ease.
- **1.5L Glass Jar:** Generous size for family servings, made from durable glass.
- **Two Programmes + Pulse:** Versatile options for a variety of blending tasks.
- **Six Satoku® Blades:** Expertly designed for optimal blending and consistency.
- **Sturdy Build:** Robust construction to handle daily use.
- **Sleek Aesthetics:** Combines functionality with an elegant design.

EMPOWER YOUR CULINARY CREATIONS

Professional Power: The SABERU 1500 boasts a high-performance 1500W motor, making quick work of even the toughest ingredients, from dense vegetables to hard ice.

Family-Sized Versatility: A spacious 1.5-liter glass jar provides ample space for large family servings, crafted from durable glass to withstand the test of daily use while maintaining the purity of flavors.

Precision and Control: Equipped with six Satoku® Blades for unparalleled blending efficiency and two versatile blending programmes plus a pulse function, the SABERU 1500 offers precise control over texture and consistency, all wrapped up in a design that's as sleek as it is functional.



1500W	1.5L	2 Presets	PULSE switch	6 Satoku® Blades	GLASS Jar

MODEL: ATB-1500		
PRODUCT CODE	BAR CODE	MASTER BOX
9182002	8435256810424	4

PERSONAL BLENDER
KITCHEN SOLUTIONS



Power	900 W
Volume Jar	1 x 600ml 1 x 450ml
Jar material	Tritan®
Blades Satoku® Patented	8

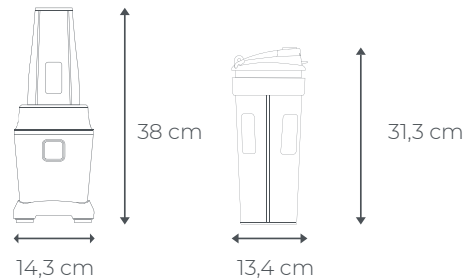

SABERU 1000

PERSONAL BLENDER ATB-1000

- **900W Power:** A step-up in performance for more demanding blending tasks.
- **Dual 600ml Tritan® Jars:** Larger capacity for increased volume or multiple servings.
- **One-Touch Operation:** Simplified control for consistent results.
- **Eight Satoku® Blades:** Double the blades for finer, more consistent textures.
- **Enhanced Stability:** Built to withstand the rigors of frequent use.
- **Ergonomic Design:** Crafted for comfortable use and handling.

YOUR PERSONAL CULINARY COMPANION

Enhanced Performance: The SABERU 1000 is equipped with a robust 900W motor, offering a significant increase in performance to handle even the most challenging blending tasks with ease.

Greater Capacity: This blender includes dual 600ml Tritan® jars, providing the perfect solution for larger recipes or multiple servings while maintaining the durability and ease of maintenance Tritan® is known for.

Precision Blending: With eight Satoku® Blades, the SABERU 1000 achieves a finer blend, ensuring even textures and consistent results, all accessible through a convenient one-touch operation. Its ergonomic design and enhanced stability make it a reliable and comfortable addition to any kitchen.



900W	600ml	2 Takeaway Bottles	TRITAN® Jar	ONE TOUCH Operation	8 Satoku® Blades
BPA Free	Anti fingerprint				

MODEL: ATB-1000		
PRODUCT CODE	BAR CODE	MASTER BOX
9183001	8435256810417	2

PERSONAL BLENDER

KITCHEN SOLUTIONS



Power	500 W
Volume Jar	2 x 600 ml
Jar material	Tritan®
Program	1 + Pulse
Blades Satoku® Patented	6

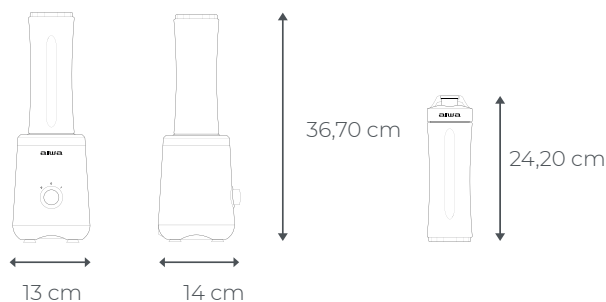

SABERU 600

PERSONAL BLENDER ATB-600

- **500W Power:** Sufficient for personal blending needs with efficient energy usage.
- **Dual 600ml Tritan® Jars:** Perfect for on-the-go lifestyles, providing durability and ease of cleaning.
- **Single Programme:** Streamlined operation for quick and effortless blending.
- **Four Satoku® Blades:** Precision-engineered for a smooth blend every time.
- **Compact Design:** Ideal for small countertops and space-saving storage.
- **Easy Maintenance:** Designed with simplicity in mind for hassle-free upkeep.

EFFICIENT POWER, CONVENIENT PORTABILITY, AND SIMPLE EFFECTIVENESS

Efficient and Powerful: The SABERU 600 is equipped with a 500W motor, providing ample power for a wide range of personal blending tasks while ensuring energy-efficient operation.

Convenient and Portable: With dual 450ml Tritan® jars, this blender is designed for active, on-the-go lifestyles. The durable and easy-to-clean jars make it perfect for those who want their nutritious blends anywhere, anytime.

Simple and Effective: The single programme feature offers a user-friendly experience, ensuring quick and effortless blending with just the touch of a button. Coupled with four precision Satoku® blades, the SABERU 600 delivers consistently smooth results, no matter the ingredients.

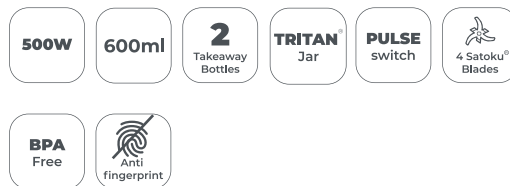

MODEL: ATB-600		
PRODUCT CODE	BAR CODE	MASTER BOX
9183002	8435256810462	8





CHOPPER
KITCHEN SOLUTIONS



Power	500 W
Speed settings	2 + Turbo
Material	Stainless Steel
Bowl material	Glass
Motor	High power and quality

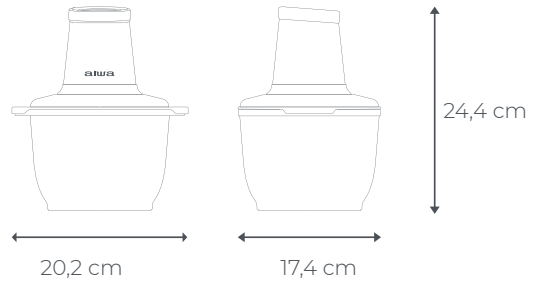

RINSAKU
CHOPPER ACP-500

- **Power:** 500W motor delivers a strong and efficient chopping experience.
- **Speed Settings:** Offers 2 speeds plus a Turbo function for customized chopping.
- **Material:** High-quality inox construction for durability.
- **Bowl Material:** Glass bowl providing a hygienic and easy-to-clean surface that maintains clarity.
- **Blades:** Includes two types of Satoku® blades for versatility in cutting different food types and achieving various cuts.
- **Design:** Lightweight and featuring a Japanese-inspired design that is both aesthetically pleasing and practical.
- **Motor:** Engineered with a high-power and high-quality motor designed for consistent and reliable use.

VERSATILITY AND POWER IN EVERY CHOP

Culinary Versatility: With two distinct Satoku® blade types, the Rinsaku Chopper can handle a wide range of foods, making it suitable for every recipe, from salsas to purées.

Powerful Precision: The 500W motor and adjustable speed settings, enhanced by the Turbo function, allow for precise control over the texture and fineness of the chop.

Design Excellence: The chopper's Japanese design is not just about looks; it integrates functional features like a high-quality motor and diverse blade options, ensuring a blend of style and performance that stands out in the kitchen.



500W	500ml	GLASS Bowl	2 Speeds	TURBO Function	2 Satoku® Blades
------	-------	------------	----------	----------------	------------------



MODEL: ACP-500		
PRODUCT CODE	BAR CODE	MASTER BOX
9185001	8435256810196	4

HAND MIXER

KITCHEN SOLUTIONS



Power	450 W
Speed settings	5 + Turbo
Accessories	2
Material accessories	Stainless Steel
Motor	High power and quality

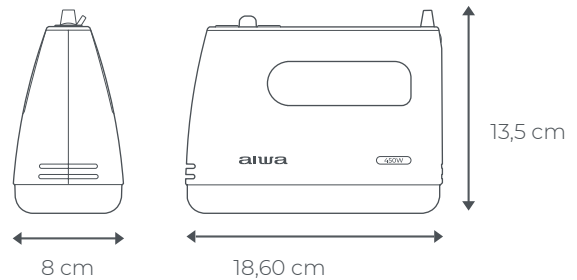

TESABERU

HAND MIXER AHX-600

- **Power:** 450W motor for powerful and efficient mixing.
- **Speed Settings:** Five variable speeds plus a Turbo function for precise control over mixing.
- **Accessories:** Includes two beaters and a dough hook, catering to a variety of baking and cooking needs.
- **Material:** Durable stainless steel accessories built to last and easy to clean.
- **Weight:** Lightweight design for comfortable handling during extended use.
- **Design and Motor:** Sleek Japanese design coupled with a high-quality motor for long-lasting performance.

ELEGANCE AND POWER IN YOUR KITCHEN

Versatile Performance: With its 450W motor and turbo function, the TeSaberu hand mixer excels in everything from whipping cream to kneading dough, making it an essential tool for any home baker.

User-Friendly: The mixer's lightweight construction is designed for ease of use, allowing for longer mixing without fatigue, and the five-speed settings provide flexibility for any recipe.

Professional Quality: Crafted with a Japanese aesthetic and high-quality stainless steel, this hand mixer doesn't just perform to professional standards—it looks sleek on your countertop too.

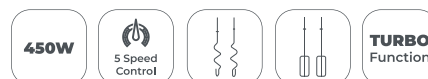

MODEL: AHX-600		
PRODUCT CODE	BAR CODE	MASTER BOX
9184001	8435256810288	12

BREAKFAST COLLECTION

MASTERFUL MORNINGS, EXQUISITE EVENINGS

AIWA proudly unveils the Gourmet Series, a testament to the meticulous Japanese attention to detail and advanced engineering. This collection redefines breakfast and cooking, marrying the simplicity of morning rituals with the sophistication of culinary artistry.

Varied Power for Culinary Adventures:

Spanning from 700W to 1600W, the toasters are designed for everything from delicate pastries to hearty artisanal bread.

Advanced Kettles for the Perfect Brew: With options like precise temperature settings and fast boiling, these kettles cater to every tea or coffee aficionado's needs.

Sandwich Artistry at Home: The Tetsu is a versatile 3-in-1 appliance, offering the ability to craft waffles, grill meats, or create the ultimate sandwich.

Grilling Refined: The Kamado grill provides a 180-degree opening, oil tray, and stainless steel construction, ensuring a seamless grilling experience.

Air Frying Accessories for Gourmet Results: Expand your culinary possibilities with accessories designed to complement your AIWA air fryer, from skewers for kebabs to pots for cakes.

Aesthetic and Functional Integrity: Every product in the Gourmet Series boasts a design that's visually appealing and functionally superior, with features like anti-fingerprint stainless steel and retro-illuminated lights.

AST



TOASTER
KITCHEN SOLUTIONS



Power	1600W
Slot width	ultra wide slot 40mm
Slot length	255 mm
Slots	2
Browning control	7 settings
Functions	Defrost, reheat, stop, timer

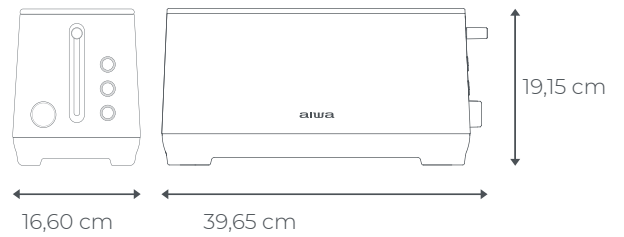

KOFOTATSU

TOASTER ABT-1600

- **Power:** 1600W
- **Slots:** 2 (Ultra Wide: 40mm, Ultra Long: 255mm)
- **Browning Levels:** 7
- **Material:** Stainless Steel with Anti-fingerprint finishing
- **Features:** Defrost, Reheat, Stop, Timer, Bun Warmer, Removable Crumb Tray, Retro-illuminated Lights, Self-centering
- **Body Material:** Stainless Steel anti finger print
- **Accessories:** Bun warmer

THE FAMILY FAVORITE MAXIMUM WATTAGE

Perfect for the bustling kitchen with high toasting demands.

Extra-Long Slots: Ideal for larger bread types or simultaneous toasting of multiple items.

Robust and Reliable: High power paired with durable construction means it's built to last.



MODEL: ABT-1600		
PRODUCT CODE	BAR CODE	MASTER BOX
9272003	8435256810172	6

TOASTER
KITCHEN SOLUTIONS



Power	1100 W
Slot width	ultra wide slot 40 mm
Slot length	255 mm
Slots	1
Browning control	7 settings
Functions	Defrost, reheat, stop, timer

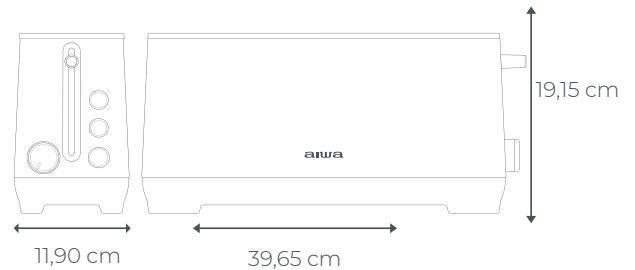

KONAGAI
TOASTER ABT-1200

- **Power:** 1100W
- **Slots:** 1 (Ultra Wide: 40mm, Ultra Long: 255mm)
- **Browning Levels:** 7
- **Material:** Stainless Steel with Anti-fingerprint finishing
- **Features:** Defrost, Reheat, Stop, Timer, Bun Warmer, Removable Crumb Tray, Retro-illuminated Lights, Self-centering
- **Body Material:** Stainless Steel anti finger print
- **Accessories:** Bun warmer

THE ARTISAN'S DELIGHT ULTRA-LONG SLOT

The KONAGAI stands out with its ultra-long slot design, accommodating a variety of bread sizes, from artisan loaves to standard slices, making it a versatile choice for different bread types and sizes.

Powerful Performance: With a 1100W output, the KONAGAI offers consistent, even browning, ensuring that every slice of toast is golden and crispy to your preference.

Sophisticated Design: The stainless steel body with an anti-fingerprint finish not only adds a modern touch to the kitchen but also makes cleaning effortless, maintaining a pristine appearance after each use.



MODEL: ABT-1200		
PRODUCT CODE	BAR CODE	MASTER BOX
9272004	8435256810165	6

TOASTER
KITCHEN SOLUTIONS



Power	1000 W
Slot width	ultra wide slot 40 mm
Slot length	140 mm
Slots	2
Browning control	7 settings
Functions	Defrost, reheat, stop, timer

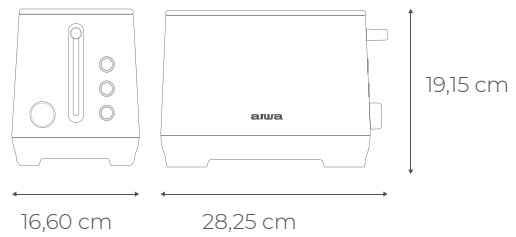

KOTAN

TOASTER ABT-1000

- **Power:** 1000W
- **Slots:** 2, ultra-wide 40mm
- **Slot Length:** 140mm
- **Material:** Stainless Steel, anti-fingerprint
- **Features:** 7 browning levels, defrost/reheat/stop/timer, bun warmer, removable crumb tray, retro-illuminated lights, self-centering slots
- **Body Material:** Stainless Steel anti finger print
- **Accessories:** Bun warmer

THE VERSATILE PERFORMER

Enhanced Power: A step up in wattage for those needing quicker and broader toasting options.

Ultra-Wide Slots: Accommodates thicker bread and pastries, ensuring flexibility for various bread types.

Sleek and Clean: Stainless steel design that resists fingerprints for a consistently polished look.



MODEL: ABT-1000		
PRODUCT CODE	BAR CODE	MASTER BOX
9272002	8435256810158	6

TOASTER
KITCHEN SOLUTIONS



Power	750 W
Slot width	35 mm
Slot length	135 mm
Slots	1
Browning control	7 settings
Functions	Defrost, reheat, stop, timer

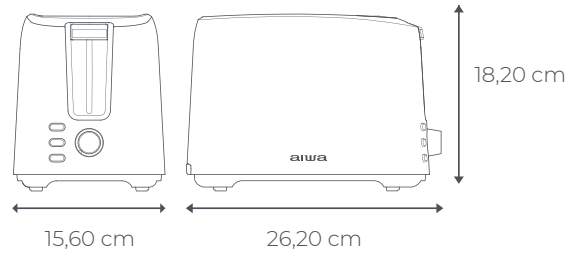

ASATAN
TOASTER ABT-700

- **Power:** 750W
- **Slots:** 2, 35mm wide
- **Slot Length:** 135mm
- **Material:** Plastic
- **Features:** 7 browning levels, defrost/reheat/stop/timer, bun warmer, removable crumb tray, retro-illuminated lights, self-centering slots
- **Body Material:** Anti-scratch ABS plastic
- **Accessories:** Bun warmer

THE COMPACT CHOICE

Perfect for those with limited space, offering essential toasting functions without compromising quality or performance.

Compact Efficiency: Ideal for small spaces, offering precise control over toasting.

Multi-Functionality: Equipped with essential toasting functions plus a bun warmer for added versatility.

User-Friendly Design: Easy cleaning and operation, highlighted by self-centering slots for even toasting.

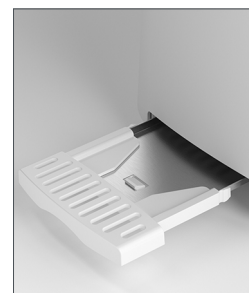

MODEL: ABT-700		
PRODUCT CODE	BAR CODE	MASTER BOX
9272001	8435256810189	6

SANDWICH & GRILL
KITCHEN SOLUTIONS

Power	1500 W
Plate size (cm)	27 x 18
Cable housing	Yes
Secure clip for vertical storage	Yes
Grill grease container	Yes

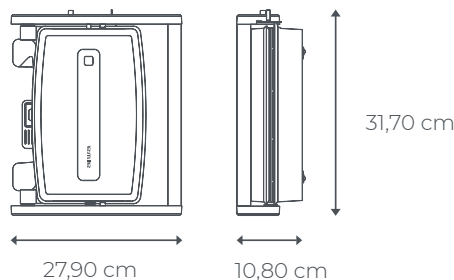

KAMADO

SANDWICH & GRILL ASM-1500G

36

- **Power:** 1500W for high-performance grilling.
- **Plate Size:** Spacious 27 x 18 cm, ideal for a variety of foods.
- **Versatility:** Versatile floating grill plate adjusts to food thickness.
- **Non-Stick Coating:** Ensures effortless cooking and easy cleanup.
- **Design:** Folds out flat for use as a double table grill.
- **Safety:** Cold-touch handle for comfortable operation without the risk of burns.
- **Body Material:** Stainless steel body with anti-fingerprint finish for durability and style.

THE GRILL MASTER'S CHOICE

Experience the power of precision grilling with the AIWA Kamado Pro. This robust 1500W grill caters to the chef in you, offering a sleek design and advanced features that turn every meal into a masterpiece. Discover the thrill of grilling, enhanced by the innovative spirit of AIWA.

Grill to Perfection: The 1500W power and adjustable plate design make it easy to grill everything to perfection, from delicate fish to thick, juicy steaks.

Easy Cleanup: Integrated dip tray and non-stick plates mean less mess and hassle-free cleaning, allowing you more time to enjoy your culinary creations.

Sophisticated and Safe: With its sleek stainless steel construction and safe, cold-touch handle, the Kamado Pro is as stylish as it is practical for indoor and outdoor use.



MODEL: ASM-1500G		
PRODUCT CODE	BAR CODE	MASTER BOX
9273001	8435256810394	4

SANDWICH & GRILL
KITCHEN SOLUTIONS

Power	750 W
3 in one	plates for waffles, grill or sandwich
Cable housing	Yes

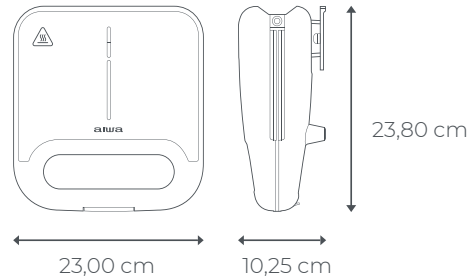

TETSU

SANDWICH & GRILL ASM-750

- **Power:** 750W for efficient cooking.
- **Versatility:** Grill, sandwich maker, and waffle iron all in one.
- **Non-Stick Coating:** Ensures easy release and swift cleaning.
- **Intelligent Design:** Indicator light for optimal cooking time.
- **Cable Housing:** Convenient and safe storage solution.
- **Body Material:** Durable stainless steel with anti-fingerprint coating.

YOUR CULINARY ALL-ROUNDER

Unlock the versatility of the AIWA Tetsu Sandwich Maker, a 3-in-1 marvel designed for the dynamic kitchen. With the ability to press sandwiches, grill ingredients, or create waffles, this appliance is a testament to AIWA's commitment to multifunctionality wrapped in a sleek design.

3-in-1 Convenience: Transition seamlessly from breakfast waffles to grilled paninis or wholesome sandwiches with interchangeable plates.

Easy to Maintain: The non-stick plates and stainless steel exterior make cleanup a breeze, keeping your kitchen spotless.

Compact and Efficient: Designed for kitchens where space is at a premium, the VersaPress doesn't compromise on power or capability, ensuring a perfect meal every time.

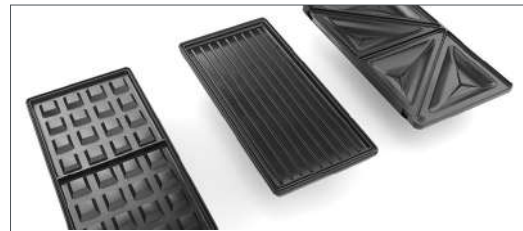

MODEL: ASM-750		
PRODUCT CODE	BAR CODE	MASTER BOX
9274001	8435256810400	4

KETTLE
KITCHEN SOLUTIONS



Power	2200 W
Capacity	1,7 L
Control	Digital
Anti burning system	Yes
Led light	Yes
Cordless 360° rotation	Yes
Temperature settings	60-70-80-90-100°C
Controller	Domestic brand

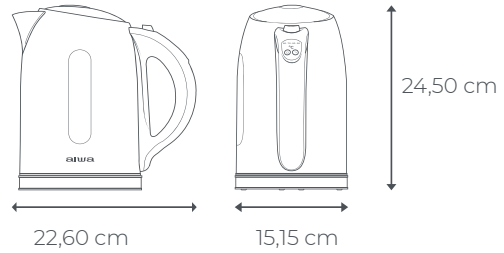

KAWAKO

KETTLE AKT-3000D

- **Power:** 2200W for quick and powerful performance.
- **Control:** Digital, with variable temperature settings (60-100°C).
- **Material:** Stainless steel with anti-fingerprint coating.
- **Capacity:** 1.7L, suitable for multiple servings.
- **Features:** Precise temperature control, keep-warm function, and illuminated water level indicator.
- **Body Material:** Stainless Steel anti finger print

THE ARTISAN'S KETTLE

Precise Control: Tailor your brewing temperature to suit a variety of teas and coffees with the digital temperature control.

Keep Warm Function: Maintains your water at the desired temperature, ready for a second cup without reboiling.

Modern Aesthetics: Full stainless steel design with temperature LED indicator adds a touch of sophistication to any kitchen.



MODEL: AKT-3000D		
PRODUCT CODE	BAR CODE	MASTER BOX
9275003	8435256810349	8

KETTLE

KITCHEN SOLUTIONS



Power	2200 W
Capacity	1 L
Control	on/off
Anti burning system	Yes
Cordless 360° rotation	Yes
Controller	Strix

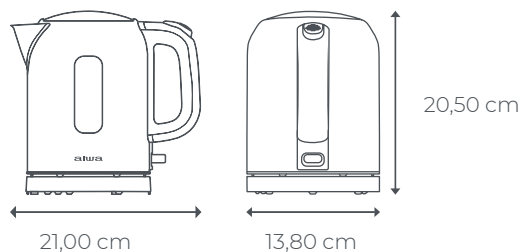

RYUJIN

KETTLE AKT-1000

- **Power:** 2200W for rapid boiling.
- **Control:** on/off for safety and convenience.
- **Material:** Stainless steel with anti-fingerprint finish.
- **Capacity:** 1L, ideal for individual use or small households.
- **Features:** Cordless 360° rotation, water level window, and automatic shut-off.

THE SWIFT AND SLEEK KETTLE

Speedy Boil: A high-wattage output for quick heating, perfect for those on-the-go.

Compact Design: The 1L capacity is perfect for minimal counter space, offering a quick boil without the bulk.

Durable Build: The anti-fingerprint stainless steel ensures your kettle remains clean and sleek in appearance.



MODEL: AKT-1000		
PRODUCT CODE	BAR CODE	MASTER BOX
9275001	8435256810325	6

KETTLE
KITCHEN SOLUTIONS



Power	2200 W
Capacity	1,7 L
Control	on/off
Anti burning system	Yes
Cordless 360° rotation	Yes
Controller	Strix

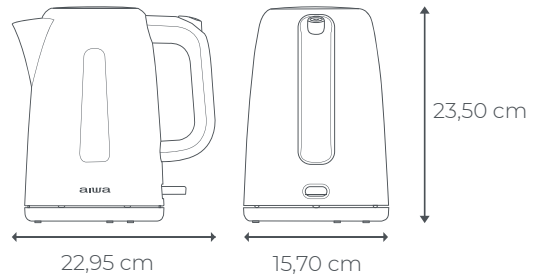

MIZUCHI
KETTLE AKT-2000

- **Power:** 2200W for efficient heating.
- **Control:** Strix automatic for reliability.
- **Material:** Durable plastic body for a lightweight feel.
- **Capacity:** 1.7L for family use.
- **Features:** Cordless design, clear water window, and automatic safety features.

THE FAMILY KETTLE

Family Friendly: With its generous 1.7L capacity, it's designed to cater to a family or those who love to host.

Safety First: The Strix control and auto-off function provide peace of mind, ensuring a safe boiling process every time.

Easy to Handle: Lightweight and cordless for ease of use, serving, and refilling.



MODEL: AKT-2000		
PRODUCT CODE	BAR CODE	MASTER BOX
9275002	8435256810332	6



CITRUS SERIES

A BLEND OF TRADITION AND INNOVATION

Step into the world of vibrant flavor and wholesome nutrition with AIWA's exceptional range of juicers. Crafted with meticulous attention to detail and infused with the renowned craftsmanship of Japanese engineering, our juicers redefine the art of extracting the purest essence from fruits and vegetables. Elevate your juicing journey with AIWA and savor every sip of nature's goodness, knowing that you're enjoying the finest quality juices.



CITRUS JUICER
KITCHEN SOLUTIONS



Power	1000 W
System	Lever-action
Filter	Adjustable
Filter material	Stainless Steel
Body material	Stainless Steel
Cone material	Stainless Steel
BPA Free	

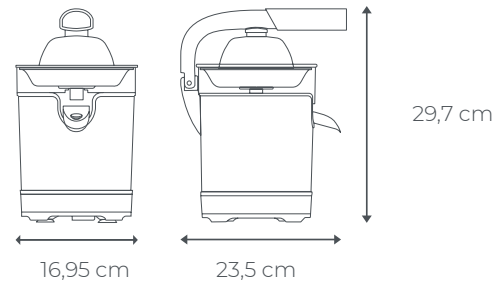

KORYU 1000

CITRUS JUICER AJC-6000

- **System:** Professional lever-action system designed for maximum efficiency.
- **Power:** A high-powered brushless 1000W motor for commercial-grade juicing.
- **Cone/Cover:** Made from stainless steel, ideal for heavy-duty use and frequent cleaning.
- **Spout:** Stainless steel spout for a clean pour every time.
- **Body material:** Solid stainless steel build, BPA-free for health-conscious users.

THE ULTIMATE IN DURABILITY AND POWER FOR PROFESSIONAL JUICING

Commercial Power: The 1000W motor is designed for juice bars and restaurants, delivering speed and power for high-volume juicing.

Ultimate Durability: Built to endure the busiest environments with a full stainless steel body and components.

Functional Elegance: A testament to Japanese design, this juicer combines functional excellence with an elegant, professional look that suits any high-end kitchen or commercial setting.



1000W	2 Cones	Stainless Steel Filter	Stainless Steel Cone	Anti - Drip	BPA Free
--------------	-------------------	------------------------	----------------------	-------------	-----------------



MODEL: AJC-6000		
PRODUCT CODE	BAR CODE	MASTER BOX
9186003	8435256810318	4

CITRUS JUICER

KITCHEN SOLUTIONS



Power	120 W
System	Lever-action
Filter	Adjustable
Filter material	Stainless Steel
Body material	Stainless Steel
Cone material big	Stainless Steel
Cone material small	Plastic

BPA Free

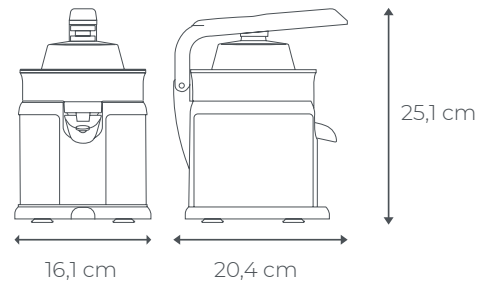

KORYU

CITRUS JUICER AJC-5000

- **System:** Lever-action for more juice extraction with less effort.
- **Power:** 120W motor, more than enough for frequent juicing.
- **Cone/Cover:** Stainless steel for maximum hygiene and oxidation prevention.
- **Body material:** Sturdy stainless steel construction to withstand heavy usage.
- **Extras:** Features anti-drip and non-slip feet for a clean and stable juicing environment.

UNLEASHING FLAVOR WITH EFFORTLESS ELEGANCE

Enhanced Extraction: Leverage the power of the KORYU's lever-action system to effortlessly extract every drop of juice.

Robust Build: With an all-stainless steel body, it's built for durability and designed to complement modern kitchen aesthetics.

Hygienic and Easy to Clean: The stainless steel components are not only hygienic but also easy to clean, ensuring your juicer remains in pristine condition.



120W	2 Cones	Stainless Steel Filter	Stainless Steel Cone	Anti-Drip	BPA Free
-------------	-------------------	------------------------	----------------------	-----------	-----------------



MODEL: AJC-5000		
PRODUCT CODE	BAR CODE	MASTER BOX
9186002	8435256810301	8

CITRUS JUICER
KITCHEN SOLUTIONS

Power	30 W
System	Traditional
Filter	Adjustable
BPA free	

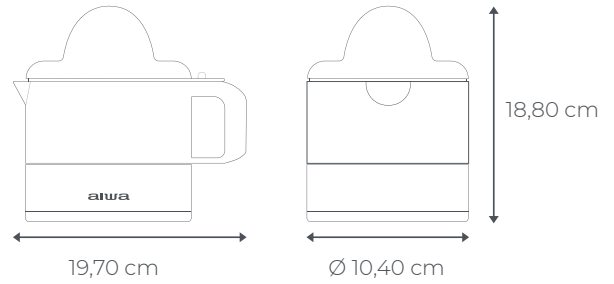

MIKAN

CITRUS JUICER AJC-4000

- **Power:** 30W motor ideal for casual, everyday use.
- **Filter:** Adjustable plastic filter to cater to different pulp preferences.
- **Cone:** Designed for effective juice extraction.
- **Body:** Durable, BPA-free plastic construction ensures safety and longevity.
- **Extras:** Comes with a cover lid to keep the juicer dust-free when not in use.

TRADITIONAL OPERATION FOR AN AUTHENTIC JUICING EXPERIENCE

Simplicity and Safety: The MIKAN juicer combines simple traditional juicing mechanics with BPA-free materials for a safe and easy juicing process.

Customizable Pulp Control: With its adjustable filter, enjoy juice just the way you like it, from smooth to pulpy.

Compact and Convenient: The MIKAN's small footprint and low power make it a perfect fit for any kitchen size, ensuring easy storage and quick clean-up.

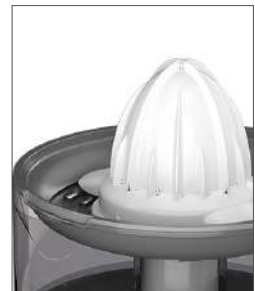
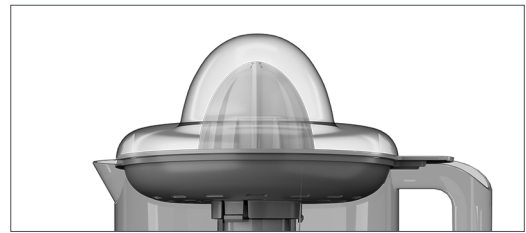

30W	500ml	double strainer	2 Cones	BPA Free
-----	-------	-----------------	---------	----------

MODEL: AJC-4000		
PRODUCT CODE	BAR CODE	MASTER BOX
9186001	8435256810295	6



AIRFRIER SERIES

INNOVATING HEALTHIER LIFESTYLES

Transform Your Cooking with AIWA Air Fryers

Delve into the world of gourmet, guilt-free cuisine with AIWA's Air Fryer Series. Where convenience meets health, this series promises to revolutionize your cooking experience, offering a smarter, faster, and healthier way to savor your favorite dishes.

Powerful Performance Across the Board: From the compact 1500W models to the formidable 2400W FUTAGO, AIWA air fryers cater to all culinary demands, combining high efficiency with powerful performance.

Robust Build with Refined Materials: The series boasts a range of materials from durable stainless steel to high-quality plastic, ensuring each air fryer is not only an aesthetic statement but also a testament to lasting durability.

Customizable Cooking with Pre-set Programs: Whether you're cooking for one or prepping for a party, the versatile pre-set programs across the AIWA series offer precision at the touch of a button, accommodating an array of cooking styles and preferences.

Exclusive Features Enhance Every Model: With characteristics like autoclean systems, double windows for cooking visibility, and super silence systems, each air fryer is designed to enhance user experience and functionality.

Design Excellence with Functionality:

Embodying the sleek, functional ethos of Japanese design, AIWA air fryers fit seamlessly into any modern kitchen, offering intuitive digital controls for effortless cooking.

Unwavering Commitment to Health and Quality:

Each air fryer in the AIWA series is a hallmark of the brand's unwavering commitment to healthier cooking, reducing oil usage by 95% without compromising on taste or quality.

Embark on a culinary journey with the AIWA

Air Fryer Series and discover the art of crafting delicious, healthy food that's as easy to make as it is satisfying to eat. Each air fryer is meticulously checked to surpass the high standards synonymous with Japanese craftsmanship, bringing you the perfect combination of style, innovation, and practicality.



AIR FRYER
KITCHEN SOLUTIONS



Power	2400 W
Capacity	9 L
Pre-sets	8
Display	Digital control
Body material	Stainless steel
Cavity type	Metal
Grill plate	Metal
Visible window	Yes
Auto clean	Yes

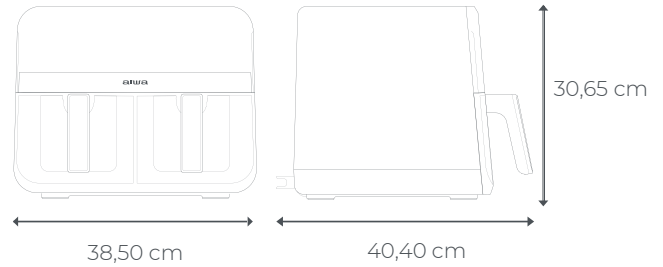

FUTAGO

AIR FRYER AFR-9000

- **Capacity:** 9L total (4.5L + 4.5L), featuring 2 baskets and 2 racks for versatile multi-tier cooking.
- **Power:** Equipped with a powerful 2400W motor, ensuring efficient and even cooking every time.
- **Material:** Crafted from high-quality stainless steel, the body of the FUTAGO 9000 is both durable and elegant, featuring an anti-fingerprint finish.
- **Pre-sets:** 8 preset programs designed to prepare a wide variety of dishes with ease.
- **Cavity:** Dual-zone cooking allows you to prepare different meals simultaneously, offering unmatched convenience.

MASTER MULTI-TASKING COOKING WITH POWER AND PRECISION

Sync Function: Synchronizes cooking times and temperatures across compartments, ensuring all dishes finish simultaneously for optimal serving.

Dual Cook Function: Allows identical settings in both baskets, doubling your cooking capacity without compromising quality.

Shaking Function: Reminds you to shake or flip food during cooking for even results and perfect crispiness.

Auto-Clean Function: Automatically cleans the interior using heat and steam, simplifying maintenance and ensuring your appliance stays in top condition.

Super Quiet System®: Enjoy ultra-quiet performance, allowing you to cook without disrupting your environment.



2400W	9L	Digital display	8 Presets	80° - 200°C	Viewing Window
Cooking Light	Defrost	Dishwasher safe	Autoclean	Dual Cooking	SYNCRO Function
SUPER Quiet System®	Anti fingerprint				

MODEL: AFR-9000		
PRODUCT CODE	BAR CODE	MASTER BOX
9171006	8435256810271	1

AIR FRYER

KITCHEN SOLUTIONS



Power	1800 W
Capacity	8 L
Pre-sets	12
Display	Digital control
Body material	Stainless steel - Plastic
Cavity type	Metal
Grill plate	Metal
Visible window	Yes
Auto clean	Yes
Double Heating System	Yes

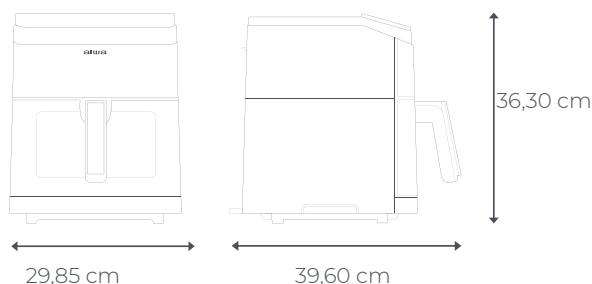

KUMADAI

AIR FRYER AFR-8000

- **Capacity:** With an 8L capacity, the KUMADAI AIR FRYER AFR-8000 is perfect for preparing generous family meals, ensuring everyone is well-fed and satisfied.
- **Power:** Powered by an 1800W motor, this air fryer strikes the perfect balance between power and energy efficiency, delivering quick and consistent results every time.
- **Material:** Its stainless steel body not only provides a sleek and modern look that complements any kitchen, but also features an anti-fingerprint finish for easy maintenance and long-lasting elegance.
- **Pre-sets:** Boasting 12 pre-set programs, the highest in its class, the KUMADAI offers unparalleled versatility for cooking enthusiasts looking to explore a wide variety of dishes, from crispy fries to succulent roasts

ELEVATE YOUR COOKING EXPERIENCE WITH DUAL RADIANT HEATING TECHNOLOGY

Dual Radiant Heating System: Heats from both the top and bottom for even cooking, precise temperature control, and faster cooking times.

Compact and Efficient Design: Offers an 8L capacity while being space-saving, making it ideal for any kitchen size.

Quiet Operation: The Super Quiet System® ensures minimal noise during use, with features like a single-zone basket and overheat protection for convenience.

Easy Maintenance: The auto-clean function uses heat and steam to clean the interior effortlessly, keeping the appliance ready for the next use.



1800W	8L	Digital display	12 Presets	80° - 200°C	Viewing Window
Cooking Light	Defrost	Dishwasher safe	Autoclean	SUPER Quiet System®	DUAL resistance
Anti fingerprint					

MODEL: AFR-8000		
PRODUCT CODE	BAR CODE	MASTER BOX
9171005	8435256810264	1

AIR FRYER
KITCHEN SOLUTIONS



Power	1800 W
Capacity	7 L
Pre-sets	8
Display	Digital control
Body material	Plastic
Cavity type	Metal
Grill plate	Metal
Visible window	Yes
Auto clean	Yes

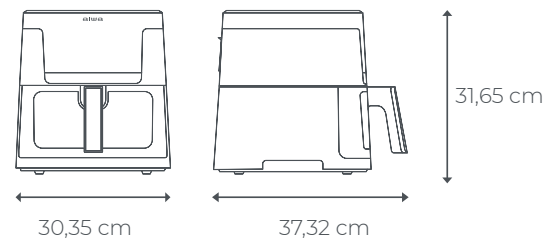

CHUKUMA
AIR FRYER AFR-7000

- **Capacity:** 7L, catering to medium-sized families.
- **Power:** 1800W for quick and thorough cooking.
- **Material:** Sturdy stainless steel construction.
- **Pre-sets:** 8 presets for a versatile cooking experience.
- **Features:** Basket system, autoclean, visible window, overheat protection, and a super silence system.
- **Super quiet system®**

EFFORTLESS COOKING FOR MEDIUM-SIZED FAMILIES

Optimal Size and Power: The CHUKUMA strikes the perfect balance between capacity and power for most households.

Stress-Free Cleaning: The autoclean feature means less time scrubbing and more time enjoying your meals.

Sleek and Simple: A combination of a simple basket system and easy-to-use digital controls ensures a hassle-free cooking process



1800W	7L	Digital display	12 Presets	80° - 200°C	Viewing Window
Cooking Light	Defrost	Dishwasher safe	Autoclean	SUPER Quiet System®	Anti fingerprint

MODEL: AFR-7000		
PRODUCT CODE	BAR CODE	MASTER BOX
9171004	8435256810257	1

AIR FRYER

KITCHEN SOLUTIONS



Power	1700 W
Capacity	6 L
Pre-sets	8
Display	Digital control
Body material	Plastic
Cavity type	Metal
Grill plate	Metal
Visible window	Yes 270°
Super silence system	Yes
Auto clean	Yes
Temperature	60-230°C
Timer	24h

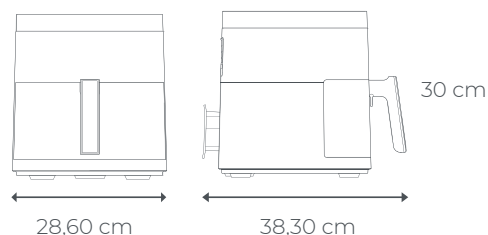

MIHARIBAN

AIR FRYER AFR-6000

- **Capacity:** 6L, compact yet spacious.
- **Power:** 1700W, delivering great performance with less power consumption.
- **Material:** Lightweight and sturdy plastic.
- **Pre-sets:** 8 presets to easily handle a variety of recipes.
- **Features:** Grill plate, 270° panoramic window, and overheat protection.
- **Super quiet system®**

EFFICIENT COOKING IN A SPACE-SAVING DESIGN

View: The unique 270° window allows you to watch your food cook from almost any angle, adding to the safety and enjoyment of use.

User-Friendly Interface: Digital controls and multiple presets make this model accessible to all users, regardless of their.



1700W	6L	Digital display	8 Presets	60° - 230°C	Panoramic Window
Cooking Light	Defrost	Dishwasher safe	Autoclean	SUPER Quiet System®	

MODEL: AFR-6000		
PRODUCT CODE	BAR CODE	MASTER BOX
9171003	8435256810240	1

AIR FRYER
KITCHEN SOLUTIONS



Power	1500 W
Capacity	5,5 L
Pre-sets	8
Display	Digital control
Body material	Plastic
Cavity type	Metal
Grill plate	Metal

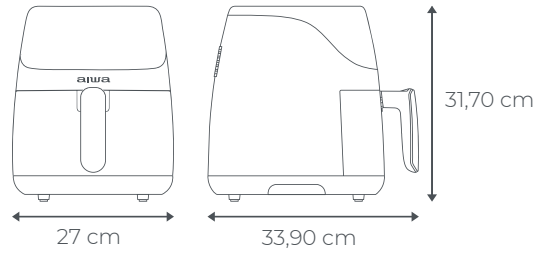

PANDA

AIR FRYER AFR-5500

- **Capacity:** 5.5L
- **Power:** 1500W, efficient for its size.
- **Material:** Durable plastic body for a lightweight feel.
- **Pre-sets:** 8 presets for various cooking methods.
- **Features:** Tray system, overheat protection, and non-slip feet.

EFFICIENT COOKING POWER FOR SMALL SPACES

Perfect Fit: The Panda's size is perfect for those with limited space who still want the versatility of an air fryer.

Simple to Use: The intuitive digital control panel makes cooking simple, with pre-set programs for common dishes.

Safe and Secure: Overheat protection and non-slip feet ensure safety during use, making it worry-free.



1500W	5,5L	Digital display	8 Presets	80° - 200°C	Dishwasher safe
-------	------	-----------------	-----------	-------------	-----------------

MODEL: AFR-5500		
PRODUCT CODE	BAR CODE	MASTER BOX
9271002	8435256810233	1

AIR FRYER

KITCHEN SOLUTIONS



Power	1500 W
Capacity	5 L
Pre-sets	7
Display	Digital control
Body material	Plastic
Cavity type	Plastic
Visible window	Yes

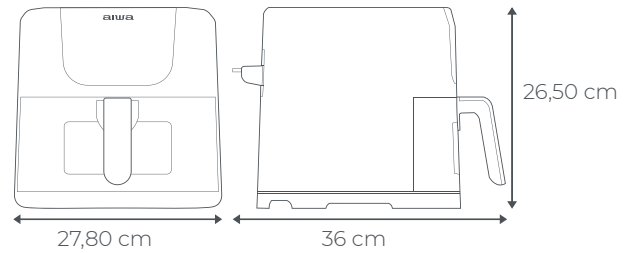

KOKUMA

AIR FRYER AFR-5000

- **Capacity:** 5L
- **Power:** 1500W, effective for its compact size.
- **Material:** Plastic body for easy maneuverability.
- **Pre-sets:** 7 cooking presets for straightforward meal preparation.
- **Features:** Tray system, visible window, overheat protection, and silent operation.

POWERFUL PERFORMANCE FOR FAMILY MEALS

Efficient and Economical: The Kokuma is energy-efficient, making it an economical choice for your energy bills.

Ease of Monitoring: With a visible window, you can easily check on your food without disrupting the cooking cycle.

Quiet Efficiency: This model is designed to operate quietly, maintaining a peaceful kitchen environment.

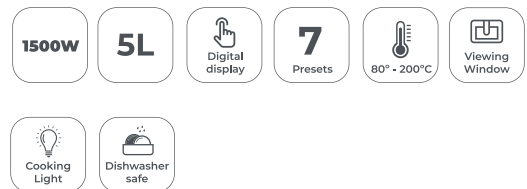

MODEL: AFR-5000		
PRODUCT CODE	BAR CODE	MASTER BOX
9171004	8435256810226	2

MULTICOOKER
KITCHEN SOLUTIONS



Power	1000W
Capacity	6L
Pre-sets	12
Digital Display	Yes
Body material	Inox
Cavity type	Inox
Pressure / Time	Customizable

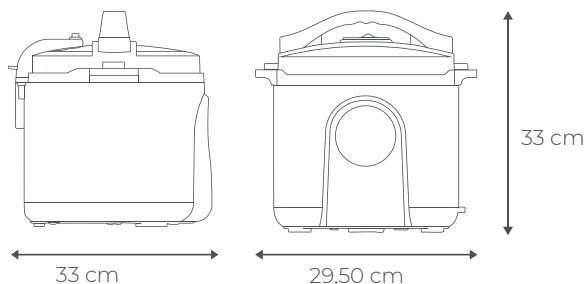

SENJU OPTIMA
MULTICOOKER MPC-600

56

- **Elegant Senshiruba Finish:** The Senju Optima features a sleek stainless steel Senshiruba design, perfectly matching the rest of your kitchen appliances.
- **12 Preset Functions with LED Touch Control:** Simplify your cooking with 12 preset functions, easily selectable via an intuitive LED touch control panel.
- **Customizable Recipes:** Personalize and save your favorite recipes, ensuring every meal is cooked to perfection.
- **Durable and Reliable Construction:** Crafted with a 1.0mm stainless steel lid, 1.0mm exterior pot, and 0.35mm steel housing, ensuring long-lasting performance.
- **Generous 6-Liter Capacity:** Ideal for preparing large meals for family gatherings or meal prepping for the week.

SENJU OPTIMA MULTICOOKER: VERSATILE AND SOPHISTICATED COOKING

Experience versatile cooking with the Senju Optima Multicooker. With 12 preset functions and an intuitive LED touch control panel, this appliance simplifies meal preparation. Its Senshiruba stainless steel finish adds elegance to your kitchen, and the 6-liter capacity is perfect for family gatherings or weekly meal prep.

You can also customize and save your own recipes, ensuring meals are tailored to your preferences. Built with a robust 1.0mm stainless steel lid and pot, and a 0.35mm steel housing, the Senju Optima ensures durability and reliable performance. The high-temperature resistant PP material ensures safe cooking every time. Elevate your cooking experience with the Senju Optima.

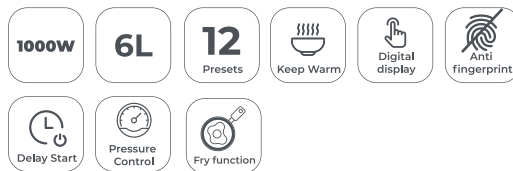

MODEL: MPC-600		
PRODUCT CODE	BAR CODE	MASTER BOX
9277002	8435256811582	2

MULTICOOKER

KITCHEN SOLUTIONS



Power	1000W
Capacity	6L
Pre-sets	22
Digital Display	Yes
Body material	Inox
Cavity type	Inox
Pressure / Time	Customizable

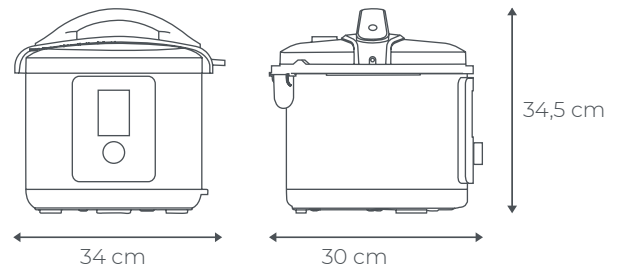

SENJU SELECT

MULTICOOKER MPC-500

- **Sleek Senshiruba Design:** Crafted with premium stainless steel, the Senju Select boasts a stylish Senshiruba finish that perfectly complements your kitchen's aesthetic.
- **22 Preset Functions:** Effortlessly prepare a wide variety of dishes with 22 convenient preset cooking programs, designed to meet all your culinary needs.
- **Customizable Recipes:** Personalize your cooking experience by customizing recipes, ensuring each meal is tailored to your taste.
- **Durable Stainless Steel Pot:** Equipped with a robust 1.0mm stainless steel lid and pot, and 0.35mm steel housing, for long-lasting durability and performance.
- **High-Pressure Cooking:** Enjoy faster and more efficient cooking with a rated pressure of 65±5kPa, perfect for tenderizing meats and infusing flavors.

SENJU SELECT MULTICOOKER: ULTIMATE VERSATILITY AND INNOVATION IN COOKING

Experience versatile cooking with the Senju Select Multicooker. Featuring 22 preset functions, it effortlessly prepares everything from stews to desserts, adapting to both culinary novices and seasoned chefs with customized recipes at the touch of a button. Its sleek Senshiruba stainless steel design enhances your kitchen's aesthetic and ensures durability.

Crafted with precision, the Senju Select includes a robust 1.0mm stainless steel lid and pot, and a 0.35mm steel housing for long-lasting performance. Rated at 65±5kPa, it reduces cooking time, perfect for busy lifestyles. The high-temperature resistant PP material ensures safe cooking. Elevate your culinary experience with this durable and stylish multicooker.

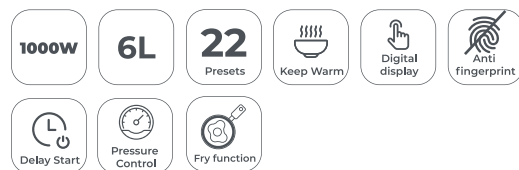

MODEL: MPC-600		
PRODUCT CODE	BAR CODE	MASTER BOX
9277001	8435256810523	2

MICROWAVES
KITCHEN SOLUTIONS



Microwave power	800 W
Grill power	1000 W
Capacity	23 L
Child LOCK function	Yes
Pre-sets	8 + Defrost
Material	Stainless Steel Front Panel
LED interior	Bright white
Easy Clean	Yes
Door Handle	Stainless Steel

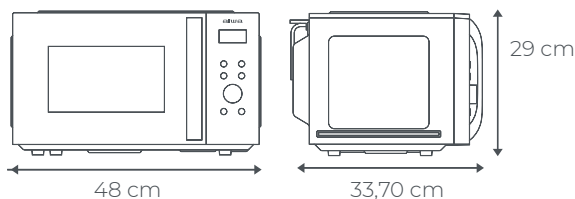

NAMICOOK CRYSTAL23
WITH GRILL

MICROWAVE MW-230DG BK

- **Capacity:** 23L
- **Power:** 800W microwave and 1000W grill function.
- **Material:** Door handle stainless steel.
- **Pre-sets:** 8 cooking+ defrost function presets for straightforward meal preparation.
- **Features:** Heavy Duty 1.0m AC-Cord with moulded AC-Plug for extra safety and convenience. Full Glass panel door and transparent viewing window, White LED digital display clock + timer with 60 minutes maximum setting
- **Accessories:** Stainless Steel Grill Rack, GLASS Turntable Plate in 25.5 cm Diameter

ELEVATING CULINARY EXCELLENCE

Discover culinary excellence with our premium digital microwave oven. Featuring a sleek black modern design and a full glass panel door, it offers 23L capacity and 800W power with grill. Enjoy effortless cooking with electronic controls and a built-in stainless steel handle.

The EASY CLEAN Stone Enamel compartment ensures easy maintenance, while bright white LED lighting saves energy.

Stay on schedule with the digital LED clock and timer, and enjoy the convenience of 8 auto cooking menus, defrost function, and instant cooking. With a 28.5cm glass turntable plate, stainless steel grill rack, and 1000W grill function, it offers versatility for all your culinary needs. Safety features include a child lock function and heavy-duty 1.0m AC cord.



800W Microwave	1000W Grill	23L	8 Presets	Express Cooking	5 Levels POWER
60 min Timer	19:51 Digital Clock	Alarm Notification	Child Lock	Viewing Window	LED Light
Defrost	25.5 cm Glass Plate	EASY To Clean			

MODEL: MW-230DG BK

PRODUCT CODE	BAR CODE	MASTER BOX
MW-230DG BK		1

MICROWAVES

KITCHEN SOLUTIONS



Power (microwave)	700 W
Power (grill)	800 W
Capacity	20 L
Child LOCK function	Yes
Pre-sets	8 + Defrost
Material	Full Glass panel door
LED interior	Bright white
Easy Clean	Yes
Accessories	2

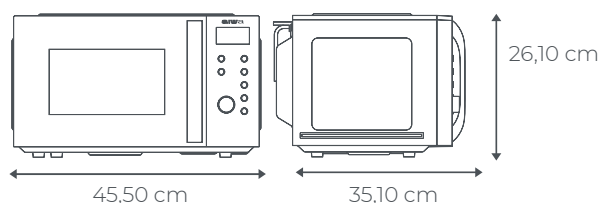

NAMICOOK CRYSTAL20 WITH GRILL

MICROWAVE MW-202DG BK

- **Capacity:** 20L, great for medium sized families
- **Power:** 700W microwave and 800W grill function,
- **Material:** Full glass panel door.
- **Pre-sets:** 8 cooking+ defrost function presets for straightforward meal preparation.
- **Features:** Heavy Duty 1.0m AC-Cord with moulded AC-Plug for extra safety and convenience. Full Glass panel door and transparent viewing window, White LED digital display clock + timer with 60 minutes maximum setting
- **Accessories:** Stainless Steel Grill Rack, GLASS Turntable Plate in 25.5 cm Diameter

VERSATILITY AND CONVENIENCE COMBINED

Introducing our versatile microwave oven, perfect for medium-sized families. With a capacity of 20L and dual-functionality of 700W microwave and 800W grill, it's ideal for various cooking needs. The full glass panel door provides a sleek look while offering durability.

Enjoy convenient meal preparation with 8 cooking presets and defrost function. Safety and convenience are prioritized with the heavy-duty 1.0m AC cord and moulded AC plug. The transparent viewing window allows you to monitor your dishes easily.

Plus, the white LED digital display clock and timer make it simple to keep track of cooking times, with a maximum setting of 60 minutes. Accessories include a stainless steel grill rack and a 25.5 cm diameter glass turntable plate. Experience hassle-free cooking with our feature-packed microwave oven.



700W Microwave	800W Grill	20L	8 Presets	5 Levels POWER	Defrost
60 min Timer	19:51 Digital Clock	Alarm Notification	Child Lock	Viewing Window	LED Light
25.5 cm Glass Plate	Steel Grill Included	EASY To Clean			

MODEL: MW-202DG BK

PRODUCT CODE	BAR CODE	MASTER BOX
MW-202DG BK		1

KITCHEN · MICROWAVES

MICROWAVES KITCHEN SOLUTIONS



Power	700 W
Capacity	20 L
Pre-sets	4 + Defrost
Material	Stainless Steel Front Panel
LED interior	Bright white
Easy Clean	Yes

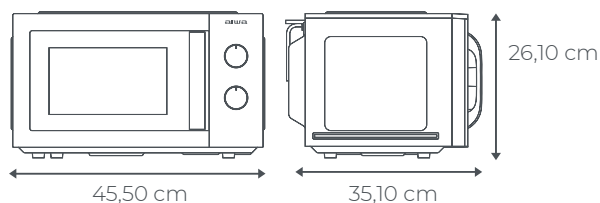

NAMICOOK SILVER20

MICROWAVE MW-200SL

- **Capacity:** 20L, suitable for individuals or small families.
- **Power:** 700W, efficient for its size.
- **Material:** Stainless Steel Front Panel with Transparent Viewing Window
- **Pre-sets:** 5 presets for various cooking methods.
- **Features:** Heavy Duty 1.0m AC-Cord with moulded AC-Plug for extra safety and convenience. Bright white LED interior compartment lighting for energy saving.

SIMPLICITY AT ITS FINEST

Introducing our latest microwave model, designed for simplicity and efficiency. With a sleek stainless steel front panel and transparent viewing window, it adds a modern touch to any kitchen. The easy-clean stone enamel cooking compartment ensures long-lasting durability.

Enjoy precise cooking control with the chrome-plated rotary power controller and convenient defrost function. Plus, the built-in door handle and rotary mechanical timer provide added convenience. Experience even heating with the glass turntable plate and bright white LED interior lighting.

With safety features like the notification bell and heavy-duty AC cord, this microwave is both compact and reliable. Experience seamless cooking with our feature-packed microwave.

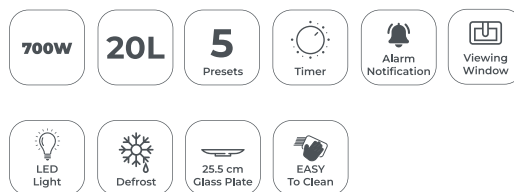

MODEL: MW-200SL

PRODUCT CODE	BAR CODE	MASTER BOX
MW-200SL		1



HOME CARE

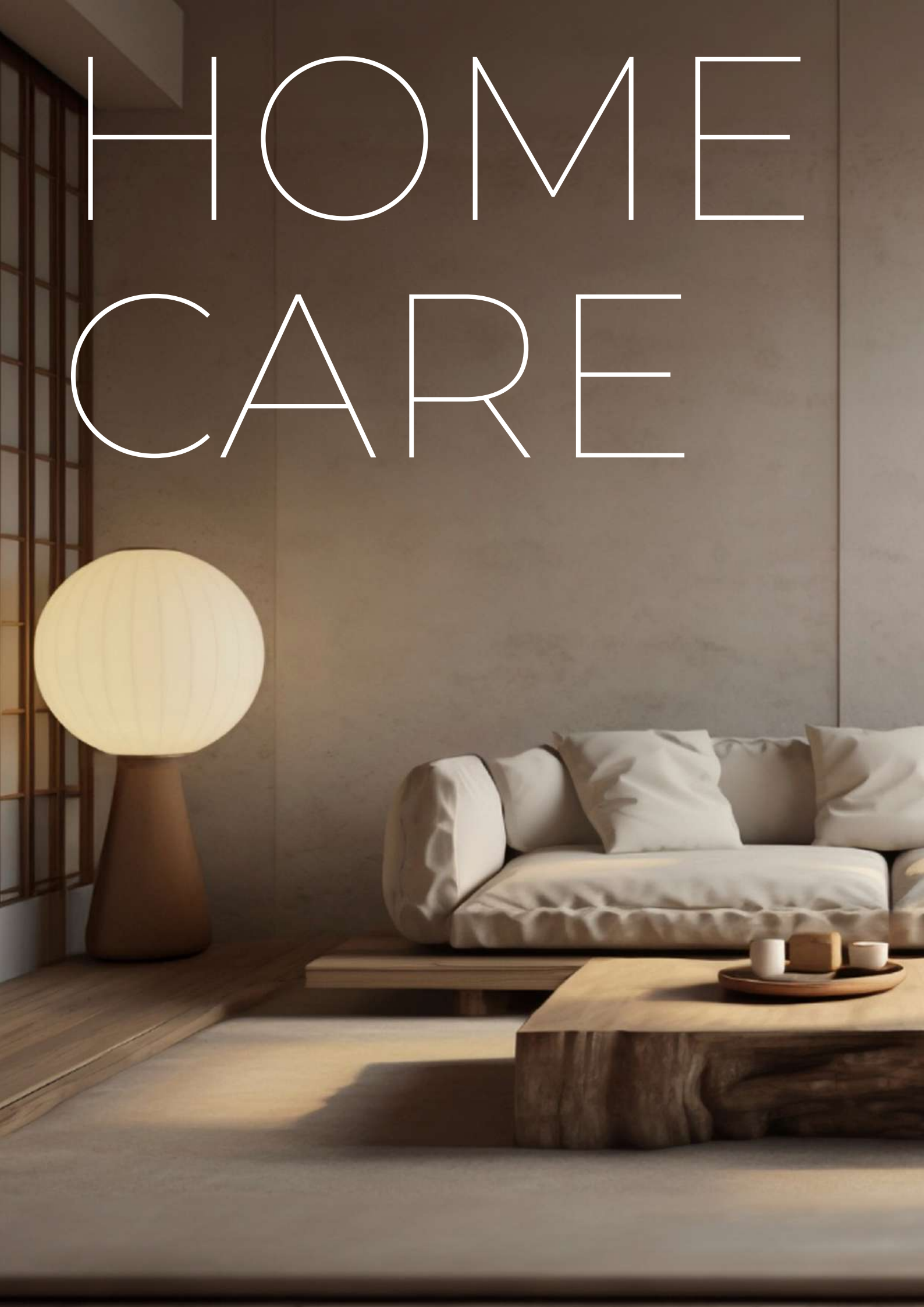



Elevate home maintenance with Aiwa's precision-engineered Home Care range. Crafted with meticulous attention to detail and inspired by Japanese craftsmanship, our appliances redefine standards. From vacuum cleaners to wet and dry devices, each embodies functionality and elegance. Trust Aiwa for effortless home care.

MIZUS



UI PRO



WET & DRY VACUUM CLEANER

HOME CARE



MIZUSUI PRO

WET & DRY VACUUM CLEANER AFC-800

INTRODUCING THE W&D MIZUSUI PRO: THE ULTIMATE HOME CLEANING SOLUTION

The W&D Mizusui Pro is the pinnacle of vacuum technology, designed to provide a comprehensive and effortless cleaning experience. This innovative Wet & Dry vacuum effortlessly handles both dry debris and liquids, and it comes equipped with a range of advanced features and multiple attachments, making any cleaning task a breeze.

Technical Specifications:

- **Suction Power:** With 11Kpa of suction strength, the W&D Mizusui Pro delivers a deep clean on any surface, from hard floors to thick carpets and upholstery.
- **Long-Lasting Battery:** Enjoy up to 60 minutes of continuous operation on a single charge, and 40 minutes at maximum power, allowing you to cover larger areas without interruptions.
- **Power:** 160W of intense suction, perfect for tackling tough stains and stubborn debris.
- **Tanks:** Featuring a 500 ml clean water tank and a 380 ml dirty water tank, the W&D Mizusui Pro ensures you can perform extended cleaning sessions without frequent emptying or refilling.
- **Self-Cleaning Technology:** Forget about the hassle of maintenance; the W&D Mizusui Pro includes a self-cleaning system in its charging base, ensuring it's always ready for the next session.

Unmatched Versatility:

The **W&D Mizusui Pro** is more than just a standard vacuum; its versatility is what sets it apart:

- **Attachments for Every Need:** It comes with a wide range of attachments, including a glass cleaner, a Spot Cleaner attachment for carpets and tough stains, and multi-purpose brushes that adapt to different surfaces, including hard-to-reach corners and crevices.
- **Fabric Functionality:** Equipped with specialized brushes that easily remove fabric stains, making cleaning sofas, curtains, and other textiles quick and effective.
- **Compact and Portable Accessories:** Includes a compact bag to carry all accessories, ensuring you always have the right tool at hand.
- **User-Friendly and Ergonomic Design:** Lightweight and easy to maneuver, the W&D Mizusui Pro is designed to make cleaning a simple and effortless task.

Power	200W
Suction	11 Kpa
Noise Level (dB)	72
Charging time	5h
Main motor	60000 rpm
Brush speed	450 rpm
Charging base	Yes
Weight (Kg)	4,8
Water tank (clean/dirty)	500ml / 380ml
Endurance time	60 min
Accessories	10

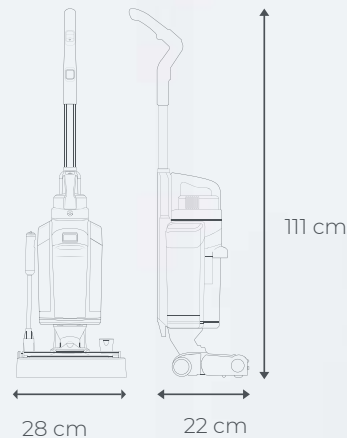

Innovation and Convenience:

- **Hygienic Materials:** Made with antibacterial materials, this vacuum not only cleans but also helps maintain a healthy environment in your home.
- **Simplified Maintenance:** Thanks to its self-cleaning technology and intuitive design, keeping your W&D Mizusui Pro in perfect condition is as easy as using it.

With the **W&D Mizusui Pro**, you'll experience deep and versatile cleaning, backed by the most advanced Wet & Dry vacuum technology. Whether you're tackling tough stains on carpets, dust in corners, or spilled liquids, the W&D Mizusui Pro is ready for any challenge, taking your home cleaning to a new level of comfort and efficiency.



18.5 V 5200 mAh Battery	200W	Cordless	40 minutes Autonomy	FLOOR Cleaning	WINDOW Cleaning	SPOT Cleaning
500ml Clean Tank	380ml Dirty Tank	5 Presets	72db	Auto-Cleaning	10 Accessories	IPX4

MODEL: AFC-800		
PRODUCT CODE	BAR CODE	MASTER BOX
9362001	8435256810219	1

HOME · WET & DRY VACUUM CLEANER

ZENKAISU SERIES

ADVANCED CLEANING SOLUTIONS PERFECTED IN JAPAN



U
|



Each Zenkaisu model is crafted to meet specific cleaning needs, combining advanced technology with user-friendly features to deliver superior cleaning performance and convenience. Whether you're tackling everyday messes or dealing with pet hair, there's a Zenkaisu vacuum designed to make your cleaning tasks easier and more **efficient**.

VACUUM CLEANER
HOME CARE



Power	500W Brushless motor (BLDC)
Suction power	300W
Charging time	2h
IA Zenkaisui mode	Yes
Led Screen	Yes
Modes	4 (min, med, max, auto)
Running time	+80 min
Station capacity	2,5 L

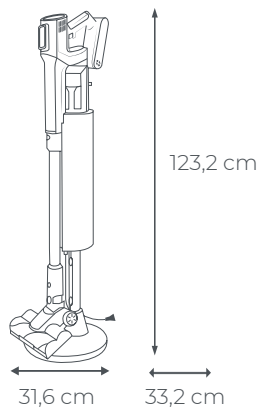

ZENKAISUI EVO 7

CORDLESS VACUUM CLEANER WITH AUTO-EMPTY STATION AVC-650

- **Power:** 800W for the strongest cleaning performance.
- **Suction Power:** 300W
- **Noise Level:** ≤78 dB for quieter operation.
- **Battery Info:** 29.6V, 8 domestic cells, 3AH
- **DC Motor Power:** 500W Brushless motor (BLDC)
- **Dust Tank Capacity:** 600ml
- **Charging Time:** Ultra-fast charging in 2 hours
- **Modes:** 4 cleaning modes (min, med, max, auto)
- **Air Inlet Filter:** HEPA + stainless steel filter
- **Innovative Design:** YES, compact and stylish
- **Removable Battery Pack:** YES
- **Runtime:** Up to 80 minutes
- **Weight:** 2.5 kg
- **Digital Screen:** YES, providing real-time information on battery life and cleaning modes.
- **Motorized Roller with LED Illumination:** YES, for hard floors and carpet
- **Self-Standing Electric Brush:** YES
- **New EB117 Energy Efficient Nozzle:** YES
- **Automatic Dust Emptying Station:** YES, for a hands-free cleaning experience



500W	Cordless	80 minutes Running Time	4000 mAh 29.6 V Battery	Ultra Fast Charging	0.4L Dust Tank Capacity
4 Presets	80db	Hepa Filter	5 Accessories	FLEX Tube	Digital display

MODEL: AVC-610		
PRODUCT CODE	BAR CODE	MASTER BOX
9361007	8435256810769	1

VACUUM CLEANER

HOME CARE



71

UNRIVALED CLEANING PERFORMANCE

Unmatched Suction Power: With an impressive 800W motor and 32Kpa suction, the AIWA EVO 7 delivers the strongest cleaning performance in its class, effortlessly removing dirt and debris from all surfaces.

Advanced Filtration: Featuring a HEPA and stainless steel filter, it captures even the finest dust particles and allergens, ensuring cleaner air and a healthier home environment.

Extended Runtime: The powerful 29.6V battery provides up to 80 minutes of continuous cleaning, ideal for large spaces and extended cleaning sessions.

Automatic Dust Emptying Station: Our innovative station automatically empties the dust tank, ensuring a hands-free and hygienic cleaning experience without the need to touch the dust.

Versatile Accessories: The vacuum comes with a motorized roller with LED illumination for hard floors and carpets, a self-standing electric brush, and a range of nozzles for versatile cleaning solutions.

Innovative Design: Combining cutting-edge technology with sleek Japanese aesthetics, the AIWA EVO 7 embodies quality and precision, delivering exceptional performance and durability.

The AIWA EVO 7 Stick Vacuum Cleaner with Auto-Empty Station is designed to bring the best of Japanese innovation and practicality into your home, making cleaning a breeze and leaving your living space spotless and fresh.

VACUUM CLEANER
HOME CARE



ZENKAISUI EVO 6
VACUUM CLEANER AVC-640

- **Battery Info:** 28,8 V@3000mAh, 8 cells
- **Noise Level:** 84 dB
- **Air Inlet Filter:** HEPA + stainless steel filter
- **Dust Tank Capacity:** 300ml
- **Accessories:** Nozzle with LED light, silver straight tube, H10HEPA filter, adapter, dust brush, crevice tool
- **Charging Base:** YES
- **Removable Battery Pack:** YES
- **IA Zenkaisui Mode:** Allows changing power device when not needed to improve working time
- **FLEX TUBE:** YES
- **Weight:** 2.5 kg
- **Motorized Roller with LED Illumination:** YES
- **Animal Kit:** YES
- **Ergonomic Handle:** YES
- **Multi-Stage Cyclone:** YES
- **Motorized Roller with LED Illumination:** YES, for hard floors and carpet

ZENKAISUI EVO 6: THE PEAK OF CLEAN

Ergonomic Design: With a weight of 2.5 kg and an ergonomic handle, the Zenkaisui EVO 6 is designed for comfort and ease of use, making it simple to maneuver around the home.

Enhanced Control: Featuring 5 cleaning modes (min, med, max, auto, turbo) and the intelligent IA Zenkaisui mode, it adapts to various cleaning needs, optimizing performance and efficiency.

Innovative Technology: The multi-stage cyclone system ensures 99.9% dust-air separation efficiency, while the LED screen provides real-time information on battery life and cleaning modes, enhancing the user experience.

Japanese Precision: Reflecting AIWA's commitment to quality and precision, the Zenkaisui EVO 6 combines cutting-edge technology with sleek design, offering exceptional performance and durability.

Power	550 W Brushless motor (BLDC)
Suction	200 AW
Noise Level (dB)	84
Ultra fast Charging time	1,5h
IA Zenkaisui mode	Yes
Speed	4 (min, med, max, turbo, auto)
Led Screen	Yes
Running time	68 min

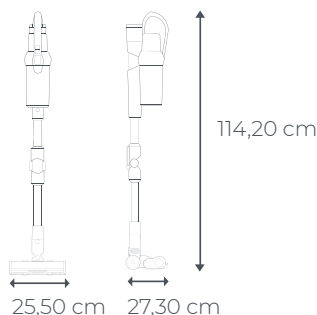

550W	Cordless	68 minutes Running Time	3000 mAh 28.8 V Battery	Ultra Fast Charging	0.3L Dust Tank Capacity
4 Speeds	84db	Hepa Filter	5 Accessories	FLEX Tube	Digital display

MODEL: AVC-640		
PRODUCT CODE	BAR CODE	MASTER BOX
9361005	8435256810486	2

VACUUM CLEANER

HOME CARE



ZENKAI SUI EVO 5

VACUUM CLEANER AVC-630

- **Battery Info:** 25,2V ~@2500mAh, 7 cells
- **Noise Level:** 80 dB
- **Air Inlet Filter:** HEPA + stainless steel filter
- **Dust Tank Capacity:** 400ml
- **Accessories:** EB111 bristled nozzle with LED light, silver straight tube, H10HEPA, adapter, dust brush, crevice tool
- **Charger Wall Bracket:** YES
- **IA Zenkaisui Mode:** YES, Allows changing power device when not needed to improve working time
- **FLEX TUBE:** YES
- **Motorized Roller with LED Illumination:** YES
- **Digital Screen:** YES
- **Animal Kit:** YES
- **Ergonomic Handle:** YES
- **Motorized Roller with LED Illumination:** YES, for hard floors and carpet

LIGHTWEIGHT POWERHOUSE

Superior Suction: Delivering 130AW suction and powered by a 500W motor, the Zenkaisui EVO 5 provides powerful cleaning performance, ideal for tackling stubborn dirt and debris.

Efficient Filtration: The HEPA and stainless steel filters ensure high air quality by capturing fine dust and allergens, making it suitable for allergy sufferers.

Comprehensive Accessories: The vacuum comes with a bristled nozzle with LED light, silver straight tube, H10HEPA filter, adapter, dust brush, and crevice tool, providing versatile cleaning solutions.

User-Friendly Features: The lightweight design (1.4 kg) and ergonomic handle make it easy to carry and maneuver, while the FLEX TUBE allows better access to dust and dirt in hard-to-reach areas.

Digital Convenience: The LED screen provides real-time information on battery life and cleaning modes, enhancing user experience.

Power	500 W Brushless motor (BLDC)
Suction	130 AW
Charging time	4-5h
IA Zenkaisui mode	Yes
Led Screen	Yes
Speed	3 (min, med, max, auto)
Running time	55 min

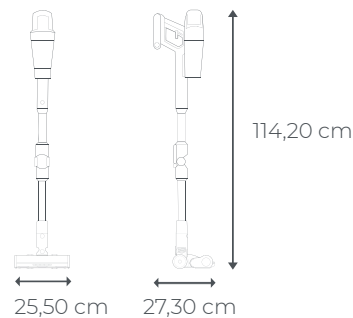

500W	Cordless	80 minutes Running Time	2500 mAh 25.2 V Battery	0.4L Dust Tank Capacity	
3 Speeds	80db	Hepa Filter	6 Accessories	FLEX Tube	Digital display

MODEL: AVC-630		
PRODUCT CODE	BAR CODE	MASTER BOX
9361004	8435256810561	2

VACUUM CLEANER
HOME CARE



ZENKAISUI EVO 4 **PET CARE**
VACUUM CLEANER AVC-620

- **Battery Info:** 25.2V Lithium-ion 3900mAh, 7 cells
- **Vacuum Power:** High speed: 32Kpa
- **Noise Level:** ≤82 dB
- **Air Inlet Filter:** HEPA + stainless steel filter
- **Dust Tank Capacity:** 600ml
- **Accessories:** Wall bracket, self-standing electric brush (S40), adapter, conductive aluminum tube, long flat crevice nozzle
- **Self-Standing Electric Brush:** YES
- **IA Zenkaisui Mode:** Allows changing power device when not needed to improve working time
- **FLEX TUBE:** Yes
- **Motorized Roller with LED Illumination:** YES
- **Digital Screen:** YES
- **Animal Kit:** YES
- **Motorized Roller with LED Illumination:** YES, for hard floors and carpet

ULTIMATE PET CARE PERFORMANCE

Enhanced Suction Power: With 120AW suction and a powerful 500W brushless motor, the Zenkaisui EVO 4 Petcare tackles pet hair and dirt effortlessly, ensuring a thorough clean every time.

Specialized Petcare Mode: Designed specifically for homes with pets, the dedicated pet care mode optimizes performance to effectively remove pet hair and allergens from all surfaces.

Comprehensive Filtration: The combination of HEPA and stainless steel filters captures even the finest pet dander and dust particles, improving indoor air quality.

Versatile Cleaning Tools: Equipped with an array of accessories, including a self-standing electric brush and long flat crevice nozzle, it's perfect for cleaning pet hair from hard-to-reach areas.

Extended Runtime: 25.2V battery provides up to 80 minutes of cleaning, ideal for homes with pets.

Power	500W Brushless motor (BLDC)
Suction	120 AW
Ultra fast Charging time	4-5 h
IA Zenkaisui mode	Yes
Speeds	3 (min, max, auto)
Mechanical brush	Yes
Running time	80 min

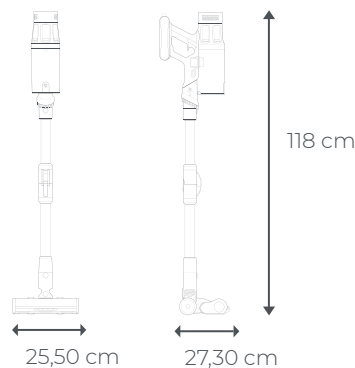

500W	Cordless	80 minutes Running Time	3900 mAh 25.2 V Battery	Ultra Fast Charging	0.6L Dust Tank Capacity
-------------	----------	--------------------------------	---------------------------------------	---------------------	--------------------------------

3 Speeds	82db	HEPA Filter	3 Accessories	FLEX Tube	Digital display
-----------------	-------------	-------------	----------------------	-----------	-----------------



MODEL: AVC-620		
PRODUCT CODE	BAR CODE	MASTER BOX
9316003	8435256810486	2

VACUUM CLEANER

HOME CARE



ZENKAI SUI EVO 4

VACUUM CLEANER AVC-610

- **Battery Info:** 29.6V Lithium-ion 3000mAh, 7 cells
- **DC Motor Power:** 500W Brushless motor (BLDC)
- **Vacuum Power:** High speed: 32Kpa
- **Suction Power:** 120AW
- **Noise Level:** ≤82 dB
- **Air Inlet Filter:** HEPA + stainless steel filter
- **Dust Tank Capacity:** 600ml
- **Accessories:** Wall bracket, self-standing electric brush (S40), adapter, conductive aluminum tube, long flat crevice nozzle
- **Self-Standing Electric Brush:** YES
- **Removable Battery Pack:** YES
- **IA Zenkaisui Mode:** Allows changing power device when not needed to improve working time
- **Motorized Roller with LED Illumination:** YES, for hard floors and carpet

EFFICIENT CLEANING COMPANION FOR EVERY HOME

Battery Life: Features a robust 29.6V 3000mAh Lithium-ion battery, providing up to 70 minutes of continuous use, ideal for extended cleaning sessions.

Motor Efficiency: Comes with a 500W brushless motor that balances power and energy efficiency, offering powerful suction while maintaining quieter operations.

Suction Capability: Achieves strong suction at 32Kpa and 120AW, efficiently removing dust, debris, and allergens.

Filtration System: Utilizes a HEPA and stainless steel filter combo to capture fine particles and clean expelled air.

Dust Tank Capacity: Includes a 600ml dust tank to minimize emptying interruptions.

Charging and Storage: Provides convenient storage with a wall bracket and features a self-standing electric brush with a 3-3,5 hour fast charging time.

Power	500W Brushless motor (BLDC)
Suction	120 AW
Ultra fast Charging time	3-3,5 h
IA Zenkaisui mode	Yes
Speeds	3 (min, max, auto)
Led Screen	Yes
Running time	70 min

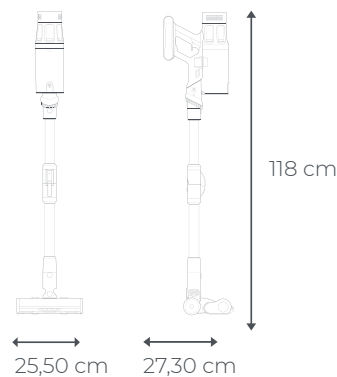

MODEL: AVC-610		
PRODUCT CODE	BAR CODE	MASTER BOX
9361002	8435256810479	2

VACUUM CLEANER
HOME CARE



Power	600 W
Dirty tank	0,9 L
Cable lenth	6 m
Tube material	Aluminium
Air inlet filter	Hepa+sponge
Noise Level (dB)	80
Accessories	4

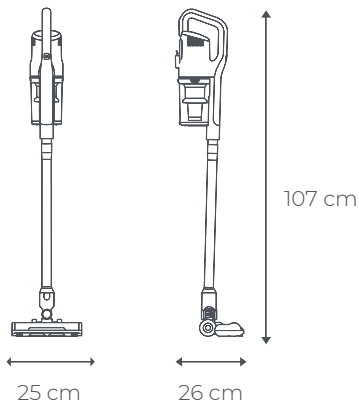

ZENKAISUI EASY MAX
VACUUM CLEANER AVC-600P

- **Power:** 600W for effective daily cleaning.
- **Cable Length:** 6 meters providing extensive reach without frequent outlet changes.
- **Tube Material:** Lightweight and durable aluminum for effortless handling.
- **Noise Level:** Operates at a comfortable 80 dB, ensuring a quieter cleaning experience.
- **Filtration:** Advanced HEPA + sponge system for superior air quality.
- **Dust Tank Capacity:** Generous 0.9L capacity, reducing the need for frequent emptying.
- **Accessories:** Comes with a plastic long tube, brush nozzle, long nozzle, and wall mount for versatile cleaning options.
- **Design:** Elegant Japanese aesthetics, combining sleekness with practical storage solutions.
- **Mechanized Brush:** Equipped with a motorized brush for enhanced deep cleaning.



600W

6m
Power Cord

80db

0.9L
Dust Tank
Capacity

Hepa Filter

4
Accessories

Motorized
Brush

ENHANCED CLEANING PERFORMANCE FOR EVERYDAY USE

Powerful Suction: The 600W motor provides ample suction power, making it ideal for daily cleaning tasks and ensuring thorough dirt and dust removal.

Advanced Filtration: Featuring a HEPA filter and sponge combination, this vacuum traps even the smallest dust particles and allergens, improving indoor air quality.

Spacious Dust Tank: The 0.9L dust tank means fewer trips to the trash, allowing for more uninterrupted cleaning sessions.

Versatile Accessories: Includes a long plastic tube for reaching high places, a standard brush nozzle for everyday use, a long nozzle for crevices and tight spaces, and a wall mount for easy storage.

Mechanized Brush: The motorized brush head agitates carpets and floors for a deeper clean, making it perfect for homes with pets and high-traffic areas.

MODEL: AVC-600P		
PRODUCT CODE	BAR CODE	MASTER BOX
9361006	8435256810752	6

VACUUM CLEANER

HOME CARE



ZENKAISUI EASY

VACUUM CLEANER AVC-600

- **Power:** 600W for effective daily cleaning.
- **Cable Length:** 6 meters to cover more area without changing outlets.
- **Tube Material:** Aluminum for a lightweight and durable build.
- **Noise Level:** 80 dB, a balanced sound for comfortable use.
- **Filtration:** HEPA + sponge for high-quality air filtration.
- **Dust Tank Capacity:** 0.9L, reducing the need for frequent emptying.
- **Accessories:** Includes a long tube, brush nozzle, long nozzle, and wall mount.
- **Design:** Sleek, light Japanese style that's easy to store and use.

POWER AND PERFORMANCE FOR EVERYDAY CLEANING

Powerful Suction: 600W motor offers ample suction for an entry-level vacuum, making it competent for everyday cleaning tasks.

Extended Reach: The 6m power cord provides a generous cleaning radius, reducing the need to switch outlets frequently.

Aluminum Tube: Durable and lightweight, the aluminum tube is designed for comfortable handling and longevity.

Filtration System: Equipped with a HEPA filter plus a sponge, it traps fine particles and allergens, releasing cleaner air back into the room.

Noise Level: Operates at 80 dB, balancing powerful suction with noise control.

Dust Tank: A 0.9L capacity dust tank means less frequent emptying and more continuous cleaning.

Accessories: Includes a long plastic tube, a standard brush nozzle, a long nozzle for crevices, and a wall mount for convenient storage.

Power	600 W
Dirty tank	0,9 L
Cable length	6 m
Tube material	Aluminium
Air inlet filter	Hepa+sponge
Noise Level (dB)	80
Accessories	4

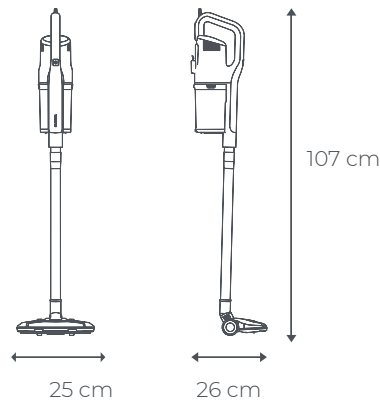

MODEL: AVC-600		
PRODUCT CODE	BAR CODE	MASTER BOX
9361001	8435256810493	6

SUMISUI SERIES

JAPANESE ENGINEERING FOR SPOTLESS RESULTS



SPOT CLEANER
HOME CARE



Power	180 W
Corded	No
Clean water tank	1,5 L
Dirty water tank	850 ml
Working time	40 min
Accessories	3
Battery	22,2V Li-ion @2200 mAh

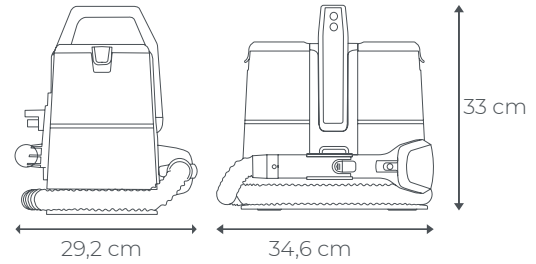

SUMISUI CORDLESS

SPOT CLEANER ASC-600

- **Type:** Cordless
- **Power:** 180W
- **Battery:** 22.2V Li-ion @ 2200mAh
- **Runtime:** 40 mins autonomy
- **Water Tank Capacity:** 850ml (dirty water tank) 1,5 L (clean water tank)
- **Accessories:** Rubber brush, silicone brush, crevice nozzle, 2-in-1 Nozzl

ENHANCED MOBILITY AND EFFICIENCY FOR SPOT CLEANING

Cord-Free Convenience: Cordless design with a 22.2V Li-ion battery provides freedom of movement.

Optimized Run Time: Up to 40 minutes of autonomy allows for thorough spot cleaning.

Portable and Lightweight: Easy to carry and use across various locations.

Compact Water Tanks: 850ml (dirty water tank) tank and 1,5L (clean water tank) offer a balance between capacity and the unit's lightweight design.



180W	1.5L Clean water	2200 mAh 22.2 V Battery	0.85L Dirty water	3 Accessories	Cordless
-------------	----------------------------	---	-----------------------------	-------------------------	----------

MODEL: ASC-600		
PRODUCT CODE	BAR CODE	MASTER BOX
9364002	8435256810387	X

SPOT CLEANER

HOME CARE



Power	600 W
Corded	Yes
Cord length	4 m
Clean water tank	850 ml
Dirty water tank	1,5 L
Accessories	3

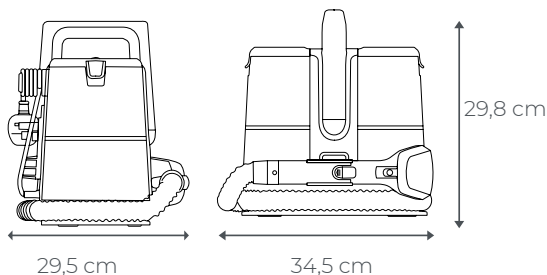

SUMISUI

SPOT CLEANER ASC-500

- **Type:** Corded
- **Power:** 600W
- **Cord Length:** 4m
- **Water Tank Capacity:** 1.5L (clean and dirty water tanks)
- **Accessories:** Rubber brush, silicone brush, crevice nozzle, 2-in-1 Nozzle

HIGH-POWERED SUCTION AND VERSATILE CLEANING SOLUTIONS

Robust Power: The 600W motor offers strong suction for tough stains.

Extended Reach: A 4m cord length allows for easy maneuverability around large areas.

Large Capacity Tanks: 1,5L Clean water tank and dirty water and 850ml dirty water tank to maximize cleaning sessions.

Versatile Cleaning Tools: A range of brushes and nozzles including a 2-in-1 nozzle cater to different cleaning surfaces.



600W	4m Power Cord	1.5L Clean water	0.85L Dirty water	3 Accessories
-------------	-------------------------	----------------------------	-----------------------------	-------------------------

MODEL: ASC-500		
PRODUCT CODE	BAR CODE	MASTER BOX
9364001	8435256810370	x

MATRESS CLEANER
HOME CARE



Power	100 W
Corded	No
Dust tank	400 ml
Filter	H10 hepa
Working time	30 min
Led display	Yes
UVC Light	Yes
Battery	11.1V Li-ion@2500mAh

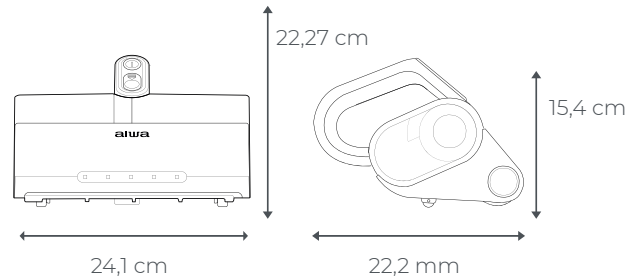

FUTONSUI CORDLESS

MATRESS CLEANER AMC-2000

- **Power:** 100 W, optimized for cordless operation.
- **Battery:** 11.1V Li-ion @ 2500mAh for up to 30 minutes of cleaning.
- **Dust Tank:** 400ml, maintain cleaning efficiency without interruptions.
- **Filtration:** H10 HEPA filter to ensure a clean and allergen-free environment.
- **Features:** LED display, UVC light for sanitization, SS filter, designed for anti-dust effectiveness.

UNLEASH THE POWER OF CORDLESS EFFICIENCY

Cordless Convenience: Freedom to clean without cords getting in the way.

Efficient Battery: Enough power for a full mattress clean on a single charge.

Sanitize as You Clean: UVC light feature for an extra layer of hygiene.



MODEL: AMC-2000		
PRODUCT CODE	BAR CODE	MASTER BOX
9363002	8435256810363	8

MATRESS CLEANER

HOME CARE



Power	500 W
Corded	Yes
Cord length	4 m
Dust tank	400 ml
Filter	H10 hepa
Led display	Yes
UVC Light	Yes

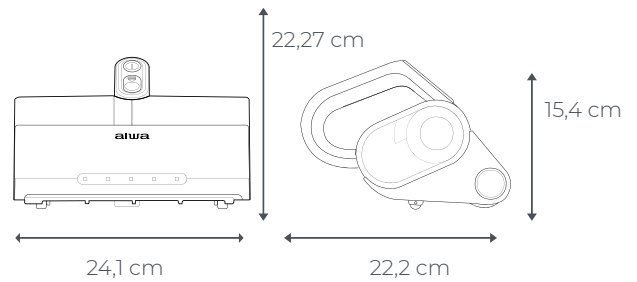

FUTONSUI

MATRESS CLEANER AMC-1000

- **Power:** 500 W for a thorough clean.
- **Cord:** 4m power cord for extended reach.
- **Dust Tank:** 400ml capacity for less frequent emptying.
- **Filtration:** H10 HEPA filter for high-efficiency allergen capture.
- **Features:** LED display, UVC light, SS filter, Japanese-engineered motorized anti-dust brush.

HARNESSING 500W FOR UNMATCHED PERFORMANCE

Deep Clean: 500W power tackles deep-seated dirt and allergens.

Long Reach: A 4m cord length allows for easy maneuverability over any mattress size.

Innovative Filtration: H10 HEPA and SS filters combine to trap dust particles effectively.



MODEL: AMC-1000		
PRODUCT CODE	BAR CODE	MASTER BOX
9363001	8435256810356	8

AIR

TREATMENT



ENT



PORTABLE AC AIR TREATMENT



Cooling capacity	9000 BTU
Heating capacity	7000BTU
Cooling power	1005W
Heating power	835W
Connectivity	WIFI
Modes	4
Electronic control	Built-in timer, sleep mode
Self-evaporating system	Yes
Remote control	Yes
Casters	Yes
Display	LED Digital



SETSUAIR

PORTABLE PAC-1000PH

- **Powerful Cooling:** 9000 BTU capacity quickly and efficiently cools spaces up to 25 square meters.
- **Smart Connectivity:** WIFI-enabled controls allow for remote temperature adjustments and scheduling via smartphone.
- **Versatile Modes:** Features *ventilation, dehumidification, heating and cooling* to create the perfect indoor atmosphere.
- **Portable Convenience:** Easily move the unit across rooms with its integrated wheels, offering flexible cooling solutions.
- **User-Friendly Operation:** Digital control panel with LED display and touch controls, along with a programmable timer and self-evaporation system for efficient use



AIWA SETSUAIR FOR YEAR-ROUND COMFORT AND ECO-FRIENDLY COOLING

Year-Round Comfort: The SETSUAIR is an all-season ally, providing refreshing breezes in summer heat and cozy warmth during winter chills, ensuring consistent comfort.

Tailored to Your Lifestyle: With its intelligent WIFI capabilities, the SETSUAIR adapts to your schedule, delivering the right temperature when and where you need it.

Eco-Friendly Technology: Combining powerful performance with environmental consciousness, the SETSUAIR utilizes eco-friendly R290 refrigerant, aligning with the green values of modern consumers.

Enhance your living space with AIWA SETSUAIR—where sophisticated design meets advanced climate control technology.



MODEL: PAC-1000PH		
PRODUCT CODE	BAR CODE	MASTER BOX
9363002	8435256900699	8

PORTABLE AC AIR TREATMENT



Cooling capacity	9000 BTU
Cooling power	1005W
Connectivity	WIFI
Modes	3
Electronic control	Built-in timer, sleep mode
Self-evaporating system	Yes
Remote control	Yes
Casters	Yes
Display	LED Digital



YUKIAIR PORTABLE PAC-1000P

- **Powerful Cooling:** 9000 BTU capacity quickly and efficiently cools spaces up to 25 square meters.
- **Smart Connectivity:** WIFI-enabled controls allow for remote temperature adjustments and scheduling via smartphone.
- **Versatile Modes:** Features ventilation, dehumidification, and cooling to create the perfect indoor atmosphere.
- **Portable Convenience:** Easily move the unit across rooms with its integrated wheels, offering flexible cooling solutions.
- **User-Friendly Operation:** Digital control panel with LED display and touch controls, along with a programmable timer and self-evaporation system for efficient use

YUKIAIR - ECO-FRIENDLY COOLING FOR QUIET, SEAMLESS INTEGRATION

Seamless Integration: The YUKIAIR fits effortlessly into any lifestyle, offering intuitive control for a consistently comfortable environment.

Eco-Conscious Cooling: With an energy efficiency of Class A and the use of R290 refrigerant, it's a choice that benefits both your home and the environment.

Quiet Comfort: The sleep mode feature ensures peaceful nights with low noise operation, making it ideal for undisturbed rest.

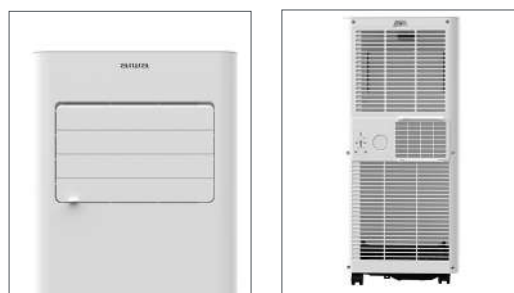

MODEL: PAC-1000P		
PRODUCT CODE	BAR CODE	MASTER BOX
9522001	8435256900538	1

PURIFIERS
AIR TREATMENT



Power	29 W
CADR	350m³/h
Room area	24-42 m³
Filter	Nylon Pre-filter H13 HEPA Active carbon filter
Negative ions	Yes
Control Panel	Touch Control with LED control panel
Speed setting	4
Weight	4,6 kg
Noise	50 db

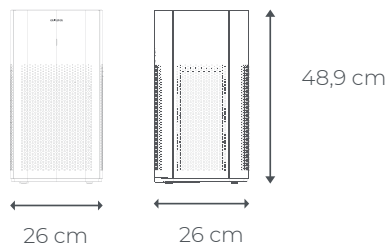

KIREIAIR 42

PURIFIERS PA-200

- **Compact Design:** Our air purifier boasts a sleek and compact design, making it a perfect fit for any space, whether it's a small bedroom or a large living room.
- **Advanced HEPA H13 Filtration:** Equipped with a high-efficiency particulate absorbing (HEPA) H13 filter, our purifier provides 99.95% filtration, effectively capturing even the tiniest 0.3-micron dust particles for cleaner, fresher air.
- **Enhanced Efficiency:** With an integrated ionizer and microfiber pre-filter, our purifier enhances filtration efficiency, ensuring that your indoor air is free from pollutants, allergens, and odors.
- **Quiet Operation:** Enjoy peace and tranquility with our purifier's ultra-quiet operation, emitting only 50dB at maximum fan speed, so you can breathe easier without any disruptive noise.
- **User-Friendly Features:** From timer functions to child lock safety features, our purifier offers user-friendly operation. With 360° air intake vents, sleep mode with reduced LED lighting, and automatic fan speed adjustment based on air quality, it's designed for convenience and ease of use.



29W	4 Presets	H13 Hepa Filter	50 dB	Replaceable Filter	1-4-8 HOURS Timer
-----	-----------	-----------------	-------	--------------------	-------------------

LED display	Child Lock
-------------	------------

CLEAN, FRESH AIR FOR YOUR HOME OR OFFICE

Our air purifier combines a compact design with advanced filtration to ensure cleaner, fresher air in your home or office. With its HEPA H13 filter and integrated ionizer, it captures 99.95% of dust particles, allergens, and odors, providing a healthier and more comfortable environment for you and your family.

MODEL: PA-200		
PRODUCT CODE	BAR CODE	MASTER BOX
PA-200	8435256897661	1

PURIFIERS
AIR TREATMENT



Power	30 W
CADR	160 m ³
Room area	11-19 m ²
Filter	Nylon Pre-filter H13 HEPA
Negative ions	Integrated IONIZER
Control Pannel	Touch Control
Speed setting	3
Weith	2.9 kg
Noise	50 db

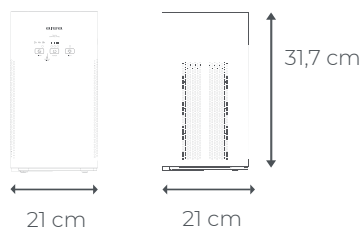

KIREIAIR 16

PURIFIERS PA-100

- **Compact:** Air Purifier with ionizer.
- **HEPA H13 Filter:** achieving 99.95% filtration for 0.3-micron dust particles.
- **Enhanced Efficiency:** Integrated Ionizer and Pre-Filter
- **Operation:** Ultra-quiet operation at 50dB, featuring 3-speed fan control and CADR of 140 m³/hour, suitable for rooms up to 16.8 m².
- **User-Friendly Operation:** User-friendly touch control panel, timer function, ambient blue nightlight, and user-replaceable HEPA filter with indicator reminder light.

OUR ELEGANT, HIGH-EFFICIENCY PURIFIER

In a world where air quality is crucial, our purifier blends elegant design with advanced filtration, ensuring 99.95% purification with its HEPA H13 filter and integrated ionizer. Its quiet operation and intuitive controls make it ideal for any space, offering peace of mind and freshness.

Designed with convenience and longevity in mind, it features user-friendly touch controls, a timer function with automatic power off, and a replaceable HEPA filter with indicator reminder light for optimal performance. With a heavy-duty AC motor and internal power supply, it's built to last, while its compact dimensions of 21 x 21 x 31.7 cm and weight of 2.9 kg make it suitable for various spaces.



30W	3 Presets	H13 Hepa Filter	50 dB	Replaceable Filter	2-4-8 HOURS Timer
LED display	Child Lock				

MODEL: PA-100		
PRODUCT CODE	BAR CODE	MASTER BOX
PA-100	8435256897654	1

DEHUMIDIFIER
AIR TREATMENT



Dehumidifying capacity (L/Day):	20L (30 °C, 80%RH), 14L (27 °C, 60% RH)
Power	270W
Water Tank	4L
Air Flow (m³/h)	170
Noise	< 45dB
Timer	0-24 hrs
Weight	15 kg
Wifi	Yes

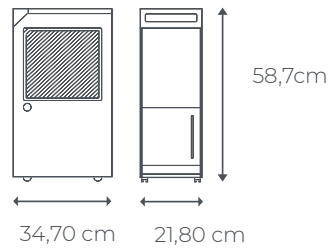

MIZUAIR 20
DEHUMIDIFIER DEF-LI20L

- **High Performance:** Dehumidifies up to 20L per day under high humidity conditions and 14L under moderate conditions.
- **Energy Efficiency:** Consumes only 270W of power.
- **Advanced Features:** 0-24 hour timer, 4L water tank, and 4 speed settings.
- **Silent and Portable:** <45dB noise level and 15kg weight.

INTRODUCING OUR HIGH-PERFORMANCE DEHUMIDIFIER

Control the humidity in your home effectively and quietly with our high-performance dehumidifier. With a dehumidifying capacity of up to 20 liters per day, this device ensures a comfortable and healthy environment, even in high humidity conditions. Its energy-efficient design consumes only 270W of power, resulting in savings on your electricity bill without sacrificing performance.

Additionally, with advanced features such as a programmable timer from 0 to 24 hours, a 4-liter water tank, and four speed settings, you'll have complete control over your surroundings. And thanks to its silent operation, with a noise level of less than 45dB, you can enjoy peace of mind at any time of day or night.

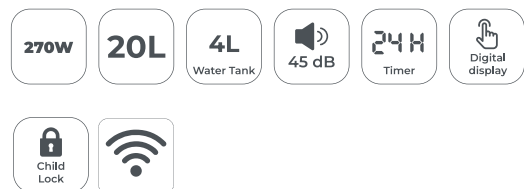
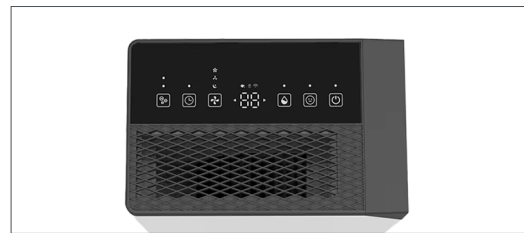

MODEL: DEF-LI20L		
PRODUCT CODE	BAR CODE	MASTER BOX
DEF-LI20L	8435256897661_Y	1

DEHUMIDIFIER

AIR TREATMENT



Dehumidifying capacity (L/Day):	12L (30°C,80%RH), 6.9L (27°C, 60% RH)
Power	158W
Water Tank	3.2L
Air Flow (m³/h)	100
Noise	< 43dB
Timer	2/4/8 hrs
Weight	11 kg
Wifi	Yes

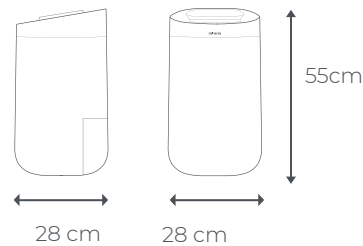

MIZUAIR 12

DEHUMIDIFIER DEF-VI12L

- **Versatile and Effective:** Dehumidifies up to 12L per day under high humidity conditions and 6.9L under moderate conditions.
- **Energy Efficient:** Consumes only 158W of power.
- **Convenient Programming:** Adjustable timer of 2, 4, or 8 hours to suit your needs.
- **Silent and Portable:** <43dB noise level and 11kg weight.

EFFORTLESS HUMIDITY CONTROL: INTRODUCING OUR EFFICIENT DEHUMIDIFIER

Take charge of your indoor comfort with ease using our efficient dehumidifier. Designed to tackle moisture in your home, this versatile appliance extracts up to 12 liters of water per day under high humidity conditions, ensuring a dry and comfortable environment for you and your family. With its energy-efficient operation consuming only 158W of power, you can enjoy optimal performance without worrying about hefty electricity bills. Plus, the convenient programmable timer allows you to customize its operation to fit your schedule, providing added convenience and flexibility.

Enjoy peace of mind knowing that our dehumidifier operates quietly with a noise level of less than 43dB, making it perfect for bedrooms, offices, and any other space where tranquility is valued. Don't let humidity control your comfort – invest in our efficient dehumidifier today and create a healthier living environment for yourself and your loved ones.



158W

12L

3.2L
Water Tank

43 dB

2-4-8
HOURS
Timer

LED
display

Child
Lock

Wifi

MODEL: DEF-VI12L		
PRODUCT CODE	BAR CODE	MASTER BOX
DEF-VI12L	8435256897654_X	1

HOME CARE · DEHUMIDIFIER

HARUAIR SERIES

THE ESSENCE OF SPRING

PRECISION COOLING AND HEATING FOR EVERY SEASON

Experience the perfect blend of efficiency and comfort with the Haruair Series. Engineered with advanced Japanese technology, these air conditioners provide exceptional energy efficiency, ensuring lower utility bills without compromising performance. The Haruair Series is designed to operate quietly, making it ideal for bedrooms, study rooms, and offices. With a compact design that seamlessly integrates into any space, and smart features like WiFi control and Turbo Cooling, the Haruair Series offers reliable, year-round comfort. Elevate your living environment with superior air quality, thanks to HEPA and stainless steel filtration systems, and enjoy a peaceful atmosphere with low noise levels and wide operating limits.





HARU AIR SERIES

94

FUNCTIONS

Turbo Cooling: Provides rapid cooling to quickly lower room temperature, ideal for hot summer days.

WiFi Control: Manage your AC unit from anywhere using a smartphone app, offering convenience and flexibility.

+8°C Heating: Keeps rooms warm during cold weather by maintaining a minimal heating temperature.

Sleep Mode: Adjusts settings to create a comfortable sleeping environment, promoting better sleep quality.

Wide Voltage Operation: Ensures reliable performance in areas with unstable voltage, protecting the unit and maintaining efficiency.





HIGHLIGHTS

Energy Efficiency: High SEER/EER ratings for cost-effective cooling and heating, making it an eco-friendly choice that reduces energy bills.

Quiet Operation: Low noise levels ensure a peaceful environment, perfect for bedrooms, study rooms, and offices.

Wide Operating Limits: Performs efficiently across a broad range of temperatures, providing reliable comfort in all seasons.

Advanced Filtration: HEPA and stainless steel filters improve indoor air quality by removing dust, allergens, and other pollutants.

Smart Features: Includes WiFi control for remote operation and Turbo Cooling for rapid temperature adjustments.

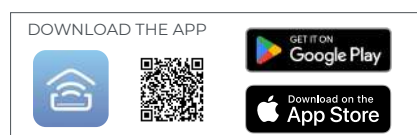

HARUAIR

HARUAIR 24

AIR CONDITIONING ACD-24000

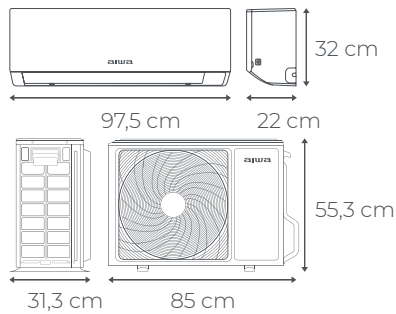

HARUAIR 18

AIR CONDITIONING ACD-18000

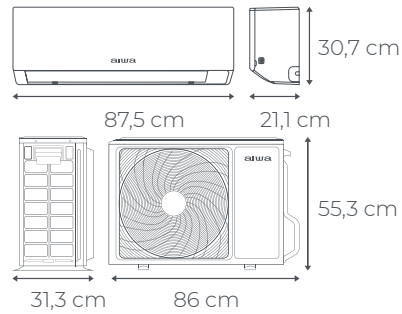

Cooling Energy Efficiency (SEER/EER)	6.70/3.10
Cooling Energy Class	A++
Heating Energy Efficiency (SCOP/COP Mild)	4.00/3.61
Heating Energy Class (Mild/Warm/Cold)	A+/A+++/-
Indoor Cooling / Heating Sound Power Level (Hi)	64 db

Cooling Energy Efficiency (SEER/EER)	6.30/2.81
Cooling Energy Class	A++
Heating Energy Efficiency (SCOP/COP Mild)	4.00/3.60
Heating Energy Class (Mild/Warm/Cold)	A+/A+++/-
Indoor Cooling / Heating Sound Power Level (Hi)	60 db

Best for large areas up to 42 square meters. Suitable for expansive living rooms or large office environments, ensuring comprehensive temperature control.

Perfect for larger rooms up to 33 square meters. Ideal for open-plan living areas or larger office spaces, providing uniform comfort.

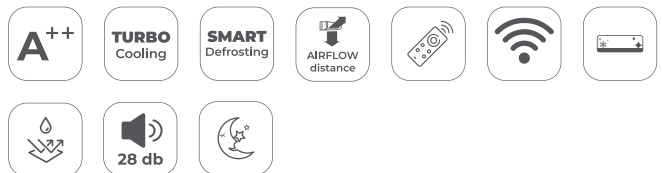
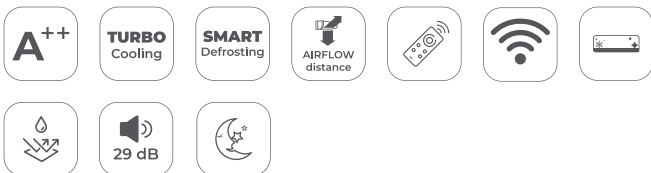

MODEL: ACD-24000		
PRODUCT CODE	BAR CODE	MASTER BOX
9521004 (I)	8435256900590	1
9521004 (E)	8435256900651	1

MODEL: ACD-18000		
PRODUCT CODE	BAR CODE	MASTER BOX
9521003 (I)	8435256900583	1
9521003 (E)	8435256900644	1

HARUAIR 12

AIR CONDITIONING ACD-12000

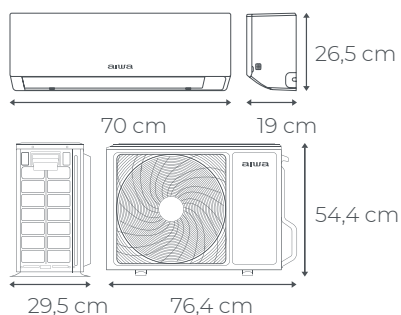

Cooling Energy Efficiency (SEER/EER)	6.10/2.81
Cooling Energy Class	A++
Heating Energy Efficiency (SCOP/COP Mild)	4.00/3.21
Heating Energy Class (Mild/Warm/Cold)	A+/A++/-
Indoor Cooling / Heating Sound Power Level (Hi)	57 db

Suitable for medium-sized rooms up to 23 square meters. Great for living rooms or larger bedrooms, offering efficient cooling and heating.

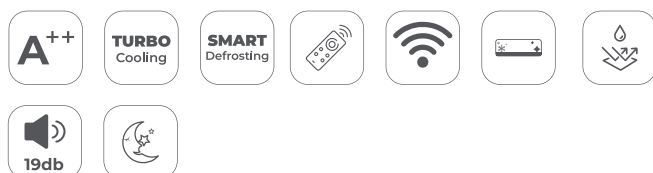

MODEL: ACD-1200		
PRODUCT CODE	BAR CODE	MASTER BOX
9521002 (I)	8435256900613	1
9521002 (E)	8435256900637	1

HARUAIR 9

AIR CONDITIONING ACD-9000

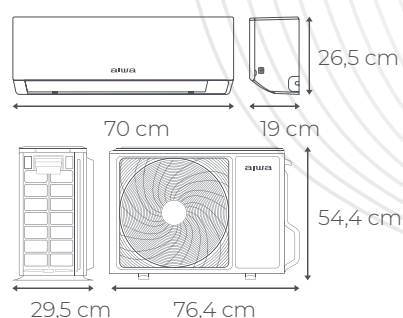

Cooling Energy Efficiency (SEER/EER)	6.1/3.01
Cooling Energy Class	A++
Heating Energy Efficiency (SCOP/COP Mild)	4/3.21
Heating Energy Class (Mild/Warm/Cold)	A+/A++/-
Indoor Cooling / Heating Sound Power Level (Hi)	54 db

Ideal for small rooms up to 14 square meters. Perfect for bedrooms or small offices, ensuring a cool, quiet environment for restful sleep or focused work.

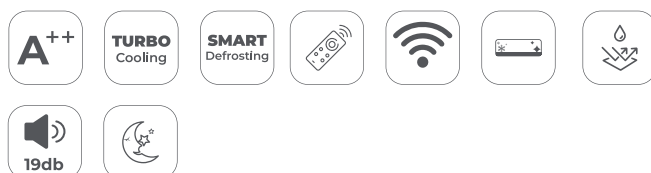

MODEL: ACD-9000		
PRODUCT CODE	BAR CODE	MASTER BOX
9521001 (I)	8435256900606	1
9521001 (E)	8435256900620	1

FUJINAIR SERIES

THE SOVEREIGN OF AIR PURITY

EXPERIENCE SUPERIOR AIRFLOW AND COMFORT WITH THE FUJINAIR SERIES

Step into a world of enhanced comfort with the Fujinair Series, where advanced airflow technology meets robust durability. These air conditioners are built to last, featuring anti-corrosive materials that withstand the harshest conditions. The Fujinair Series offers strong, uniform cooling and heating, eliminating hot and cold spots for consistent comfort throughout your space. With smart features like Auto Mode, which adjusts settings based on ambient conditions, and the innovative 3D Airflow system that ensures even air distribution, the Fujinair Series provides a seamless and eco-friendly cooling solution. Ideal for various room sizes, these units combine triple filtration technology to deliver cleaner, healthier air.





FUJINAIR SERIES

100

FUNCTIONS

Triple Filter Tech: Combines multiple filtration systems to enhance air purity, capturing dust, pollen, and other airborne particles.

Auto Mode: Automatically adjusts cooling or heating settings based on current room conditions, ensuring consistent comfort with minimal effort.

Anti-Corrosion: Special coating protects the unit from rust and corrosion, extending its durability and reducing maintenance needs.

Wide Voltage Operation: Maintains stable operation even with fluctuating voltage, ensuring reliable performance and protecting the unit.

Sleep Mode: Enhances nighttime comfort by adjusting temperature and airflow to promote better sleep.

3D Airflow: Synchronizes horizontal and vertical deflectors to evenly distribute air throughout the room, enhancing comfort and efficiency.





HIGHLIGHTS

Enhanced Airflow: Strong airflow system ensures uniform cooling and heating, eliminating hot or cold spots and enhancing overall comfort.

Durable Build: Constructed with anti-corrosive materials, these units are built to last, reducing maintenance costs and extending the lifespan of the AC unit.

Smart Operation: Features like Auto Mode and integrated structure simplify operation by automatically adjusting settings based on ambient conditions.

Eco-Friendly: Utilizes energy-efficient components and refrigerants, minimizing its ecological footprint while maximizing performance.

Comprehensive Filtration: Triple filter technology removes more impurities from the air, enhancing indoor air quality.

3D Airflow: Delivers air vertically and horizontally, ensuring even distribution throughout the room for comprehensive cooling and heating coverage.



DOWNLOAD THE APP



GET IT ON
Google Play

Download on the
App Store

FUJINAIR

FUJINAIR 24

AIR CONDITIONING ACD-24100

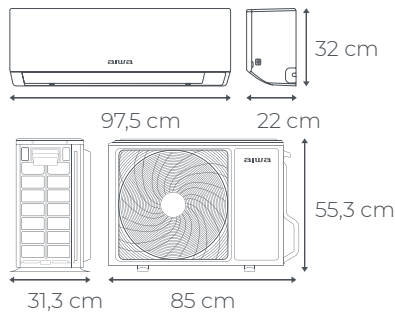

FUJINAIR 18

AIR CONDITIONING ACD-18100

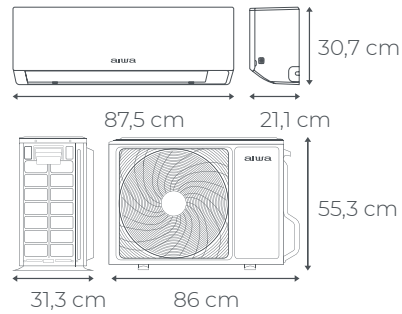

Cooling Energy Efficiency (SEER/EER)	6.70/3.10
Cooling Energy Class	A++
Heating Energy Efficiency (SCOP/COP Mild)	4.00/3.61
Heating Energy Class (Mild/Warm/Cold)	A+/A+++/-
Indoor Cooling / Heating Sound Power Level (Hi)	64 db

Cooling Energy Efficiency (SEER/EER)	6.30/2.81
Cooling Energy Class	A++
Heating Energy Efficiency (SCOP/COP Mild)	4.00/3.60
Heating Energy Class (Mild/Warm/Cold)	A+/A+++/-
Indoor Cooling / Heating Sound Power Level (Hi)	60 db

Perfect for large spaces up to 42 square meters. Best for expansive living rooms or large offices, providing comprehensive air distribution and maintaining a comfortable environment

Ideal for larger rooms up to 33 square meters. Great for open-plan living areas or large offices, the 3D Airflow feature ensures that air reaches every part of the room.

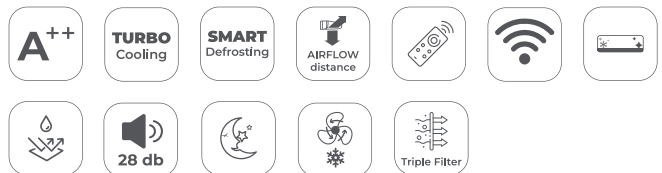
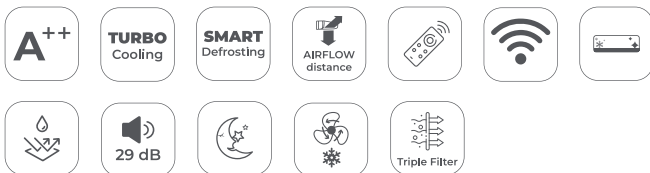

MODEL: ACD-24100		
PRODUCT CODE	BAR CODE	MASTER BOX
9521008 (I)	8435256810882	1
9521008 (E)	8435256810899	1

MODEL: ACD-18100		
PRODUCT CODE	BAR CODE	MASTER BOX
9521007 (I)	8435256810868	1
9521007 (E)	8435256810875	1

FUJINAIR 12

AIR CONDITIONING ACD-12100

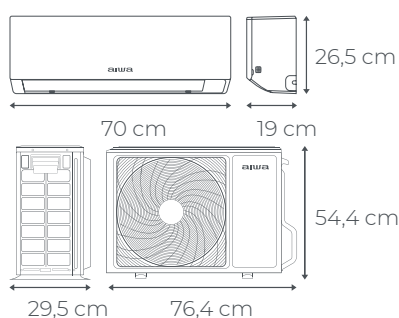

Cooling Energy Efficiency (SEER/EER)	6.10/2.81
Cooling Energy Class	A++
Heating Energy Efficiency (SCOP/COP Mild)	4.00/3.21
Heating Energy Class (Mild/Warm/Cold)	A+/A++/-
Indoor Cooling / Heating Sound Power Level (Hi)	57 db

Suitable for medium rooms up to 23 square meters. Ideal for larger bedrooms or living rooms, the enhanced airflow system ensures consistent comfort throughout the space.

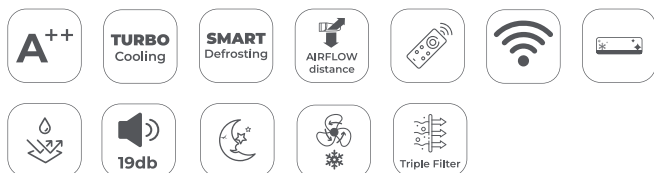

MODEL: ACD-12100		
PRODUCT CODE	BAR CODE	MASTER BOX
9521006 (I)	8435256810844	1
9521006 (E)	8435256810851	1

FUJINAIR 9

AIR CONDITIONING ACD-9100

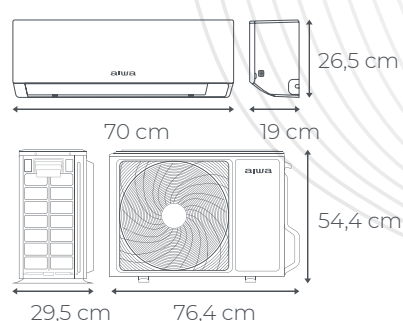

Cooling Energy Efficiency (SEER/EER)	6.1/3.01
Cooling Energy Class	A++
Heating Energy Efficiency (SCOP/COP Mild)	4/3.21
Heating Energy Class (Mild/Warm/Cold)	A+/A++/-
Indoor Cooling / Heating Sound Power Level (Hi)	54 db

Best for small rooms up to 14 square meters. Perfect for compact spaces, this model ensures every corner of the room receives cool or warm air evenly.

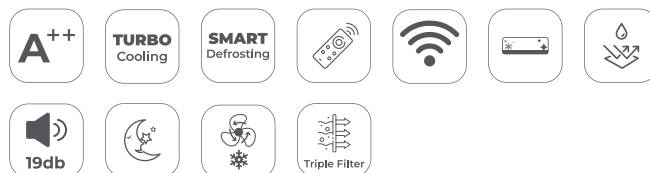

MODEL: ACD-9100		
PRODUCT CODE	BAR CODE	MASTER BOX
9521005 (I)	8435256810820	1
9521005 (E)	8435256810837	1

SUIJINAIR SERIES

THE MASTER OF ELEMENTAL COMFORT

UNVEIL THE PINNACLE OF AIR PURIFICATION AND EFFICIENCY
WITH THE SUIJINAIR SERIES

The SuijinAir Series represents the epitome of innovation and efficiency in air conditioning. Designed with advanced Japanese engineering, these units boast superior SEER/EER ratings for remarkable energy savings. The SuijinAir Series operates quietly, creating a serene environment perfect for both residential and commercial spaces. Featuring cutting-edge technologies like +8°C heating for cold climates and Turbo Cooling for immediate relief on hot days, these air conditioners ensure optimal comfort. The standout feature, Aqua Sterilization, uses ionization to purify the air, making it healthier and cleaner. Compact and stylish, the SuijinAir Series fits seamlessly into any décor, providing robust filtration and smart control via WiFi for ultimate convenience.

R



SUIJIN AIR SERIES

106

FUNCTIONS

+8°C Heating: Maintains a low heat setting to prevent freezing, making it suitable for colder climates.

Turbo Cooling: Rapidly reduces room temperature for immediate comfort, perfect for hot summer days.

Self Clean: An automatic cleaning function that ensures the unit remains efficient and hygienic by reducing dust and moisture build-up.

Anti-Corrosion: Protects the unit from rust and corrosion, enhancing durability and longevity.

Smart Control: Features WiFi control for remote operation, allowing you to adjust settings from anywhere using your smartphone.

Aqua Sterilization: Uses advanced ionization technology to sterilize the air, removing harmful particles and improving overall air quality. better sleep.

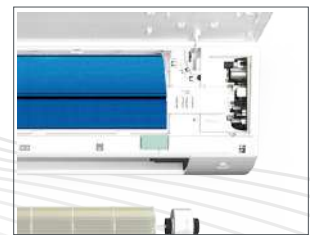



HIGHLIGHTS

High Efficiency: Superior SEER/EER ratings offer exceptional energy savings without compromising performance, making it a cost-effective choice for both home and office use.

Quiet Performance: Operates at minimal noise levels, creating a tranquil environment ideal for living rooms, bedrooms, and offices.

Innovative Features: Equipped with advanced technology like +8°C heating and Turbo Cooling, providing rapid temperature adjustments and efficient heating solutions.

Compact and Stylish: Modern design complements any interior décor, making these units both aesthetically pleasing and space-efficient.

Robust Filtration: Dual filtration systems enhance air quality by effectively removing dust, allergens, and other pollutants.

Aqua Sterilization: Uses ionization to sterilize the air, providing a healthier and cleaner indoor environment by removing harmful particles.



SUIJINAIR

SUIJINAIR 24

AIR CONDITIONING ACD-24200

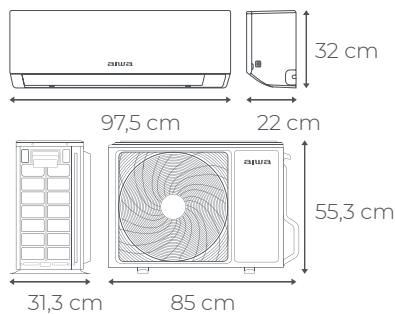

SUIJINAIR 18

AIR CONDITIONING ACD-18200

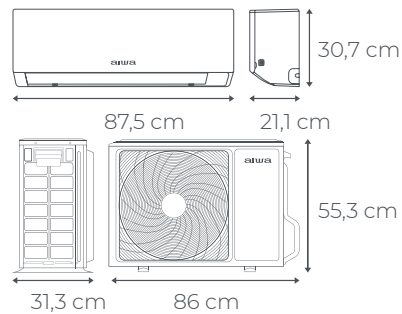

Cooling Energy Efficiency (SEER/EER)	6.70/3.10
Cooling Energy Class	A++
Heating Energy Efficiency (SCOP/COP Mild)	4.00/3.61
Heating Energy Class (Mild/Warm/Cold)	A+/A+++/-
Indoor Cooling / Heating Sound Power Level (Hi)	64 db

Cooling Energy Efficiency (SEER/EER)	6.30/2.81
Cooling Energy Class	A++
Heating Energy Efficiency (SCOP/COP Mild)	4.00/3.60
Heating Energy Class (Mild/Warm/Cold)	A+/A+++/-
Indoor Cooling / Heating Sound Power Level (Hi)	60 db

Perfect for very large areas up to 42 square meters. Suitable for expansive living rooms or open-plan offices, offering superior air quality and consistent comfort.

Best for larger spaces up to 33 square meters. Ideal for big living areas or large offices, the advanced filtration and sterilization ensure a comfortable and healthy environment.

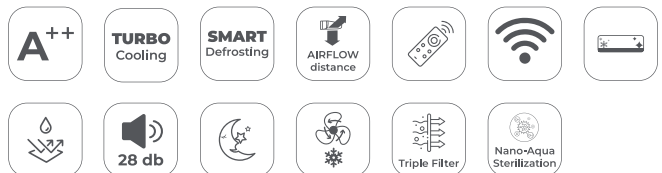
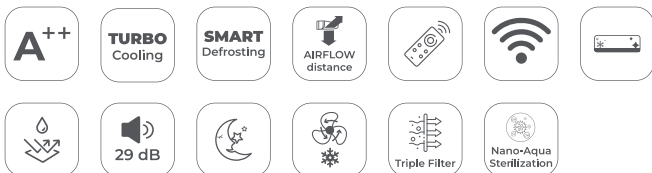

MODEL: ACD-24200		
PRODUCT CODE	BAR CODE	MASTER BOX
9521012 (I)	8435256810967	1
9521012 (E)	8435256810974	1

MODEL: ACD-18200		
PRODUCT CODE	BAR CODE	MASTER BOX
9521011 (I)	8435256810943	1
9521011 (E)	8435256810950	1

SUIJINAIR 12

AIR CONDITIONING ACD-12200

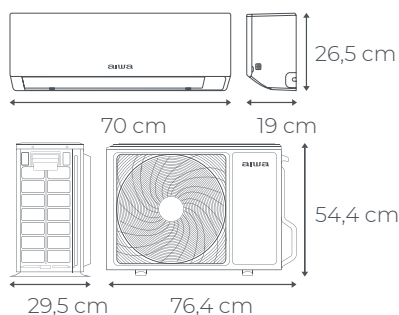

SUIJINAIR 9

AIR CONDITIONING ACD-9200

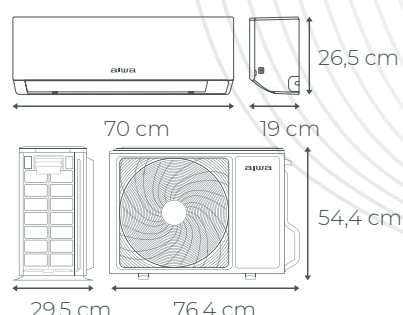

Cooling Energy Efficiency (SEER/EER)	6.10/2.81
Cooling Energy Class	A++
Heating Energy Efficiency (SCOP/COP Mild)	4.00/3.21
Heating Energy Class (Mild/Warm/Cold)	A+/A++/-
Indoor Cooling / Heating Sound Power Level (Hi)	57 db

Cooling Energy Efficiency (SEER/EER)	6.1/3.01
Cooling Energy Class	A++
Heating Energy Efficiency (SCOP/COP Mild)	4/3.21
Heating Energy Class (Mild/Warm/Cold)	A+/A++/-
Indoor Cooling / Heating Sound Power Level (Hi)	54 db

Suitable for rooms up to 23 square meters. Great for living rooms or larger bedrooms, providing efficient cooling and heating while maintaining air purity.

Ideal for small spaces up to 14 square meters. Perfect for bedrooms or small offices, ensuring cool and clean air with Aqua Sterilization for enhanced health benefits.

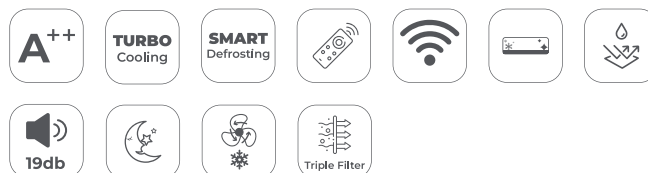
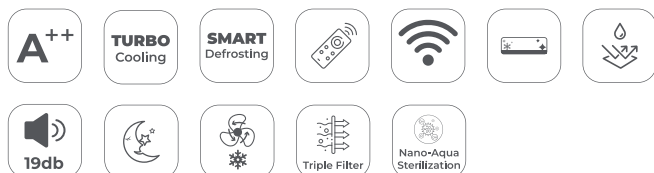

MODEL: ACD-12200		
PRODUCT CODE	BAR CODE	MASTER BOX
9521010 (I)	8435256810929	1
9521010 (E)	8435256810936	1

MODEL: ACD-9200		
PRODUCT CODE	BAR CODE	MASTER BOX
9521009 (I)	8435256810905	1
9521009 (E)	8435256810912	1

MODEL

		Nominal (Min-Max)	kW
	Energy Efficiency	SEER/EER	
	Energy Class		
	Pdesign Capacity		kW
	Power Input	Nominal (Min-Max)	kW
	Annual Energy Consumption		kWh/a
	Operating Limits	Min-Max	°C
HEATING	Capacity	Nominal (Min-Max)	Btu/h
	Capacity	Nominal (Min-Max)	kW
	Energy Efficiency	SCOP/COP (Mild)	
		SCOP (Warm/Cold)	
	Energy Class	Mild/Warm/Cold	
	Pdesign Capacity (-10°C)		kW
	Power Input	Nominal (Min-Max)	kW
	Annual Energy Consumption		kWh/a
	Operating Limits		°C
	Power Supply	Ph/V/Hz	
	Position		
INDOOR	Net Dimension	W/D/H	mm
	Package Dimension	W/D/H	mm
	Net/Shipping Weight		kg
	Air Flow (Cooling/Heating)	Max	m ³ /h
	Sound Power Level	Cooling (Hi)	dB(A)
		Heating (Hi)	dB(A)
	Sound Pressure Level	Cooling (Hi/Mid/Lo/So)	dB(A)
		Heating (Hi/Mid/Lo/So)	dB(A)
Moisture Removal		10-3m ³ /h	
OUTDOOR	Compressor		
	Net Dimension	W/D/H	mm
	Package Dimension	W/D/H	mm
	Net/Shipping Weight		kg
	Air Flow (Cooling/Heating)	Max	m ³ /h
	Sound Power Level	Hi	dB(A)
	Sound Pressure Level	Hi	dB(A)
	Running Current	Max	A
	Refrigerant Type	R410a/R32	
	Refrigerant Charge	R410a/R32	g
	Refrigerant Pipe	Liquid Side Diameter	mm
		Gas Side Diameter	mm
		Max Pipe Length/Height	m
		Max Pipe Length without Additional Charge	m
	Additional Charge	g/m	

HARUAIR 9 FUJINAIR 9 SUJINAIR 9	HARUAIR 12 FUJINAIR 12 SUJINAIR 12	HARUAIR 18 FUJINAIR 18 SUJINAIR 18	HARUAIR 24 FUJINAIR 24 SUJINAIR 24
2.5(0.8-3.0)	3.20(0.80-3.50)	4.80(1.30-5.40)	6.20(1.30-7.40)
6.1/3.01	6.10/2.81	6.30/2.81	6.70/3.10
A++	A++	A++	A++
2.5	3.20	4.80	6.20
0.83(0.3-1.2)	1.138(0.30-1.50)	1.708(0.40-1.90)	2.000(0.40-2.20)
143	184	267	324
-10-43°C(out)	-10-43°C(out)	-15-43°C(out)	-15-43°C(out)
9550(2730-11260)	11600(2730-12280)	16380(4430-18420)	21500(4770-25590)
2.8(0.8-3.3)	3.40(0.80-4.00)	4.80(1.30-5.40)	6.30(1.40-7.50)
4/3.21	4.00/3.21	4.00/3.60	4.00/3.61
4.60/-	4.60/-	5.10/-	5.10/-
A+/A++/-	A+/A++/-	A+/A+++/-	A+/A+++/-
2.1	2.60	3.60	4.60
0.872(0.3-1.2)	1.059(0.30-1.50)	1.333(0.40-1.90)	1.745(0.60-2.30)
735	910	1260	1610
-15-24°C(out)	-15-24°C(out)	-15-24°C(out)	-15-24°C(out)
1/220-240/50	1/220-240/50	1/220-240/50	1/220-240/50
indoor	indoor	outdoor	outdoor
705/193/265	705/193/265	875/212/304	975/222/318
772/325/263	772/325/263	945/390/296	1050/397/301
7.5/8.8	7.8/9.2	10.0/12.0	11.6/14.4
520/520	520/520	770/810	1100/1000
54	57	60	64
54	57	60	64
38/34/30/18	39/35/31/19	44/40/35/28	47/45/37/29
38/34/30/18	39/35/31/19	44/40/35/28	47/45/37/29
1.2	1.4	2	2.8
HIGHLY	HIGHLY	SANYO	HIGHLY
700/245/544	700/245/544	800/275/553	800/275/553
819/320/585	819/320/585	902/375/607	902/375/607
21.8/23.9	22.9/25	29.2/32.1	32.7/36.5
2100/2100	2100/2100	2200/2200	2500/2500
62	63	65	68
50	50	54	57
5.3	6.5	8.6	10.5
R32	R32	R32	R32
500	550	780	900
6.35	6.35	6.35	6.35
9.52	9.52	12.7	12.7
20/10	20/10	20/15	25/15
5	5	7	7
20	20	20	20

FUNCTIONS	INTRODUCTION	
TOSEI AQUA Sterilization	Ionizes the air and releases positive and negative ions to sterilize the air with efficiency up to 97.5%.	
Triple filter tech	Utilizes mixed powerful filter plus electronic filter, combining to prevent the air conditioner from harmful micro-particles including dust, virus and bacteria	
Anti-Corrosion	Helps condensate flow smoothly via its hydrophilic and anti-corrosive properties.	
Self Clean	Freezes the evaporator with moisture in the air, and then removes away dirt in melting, ensuring clean air out of the air conditioner.	
WiFi Control	Download the Tuya Intelligent Air App to an Apple or Android smart device, and link the equipment to the smart device for system control from whenever and wherever you want.	
A-PAM Control	Automatically adjusts DC bus voltage in accordance with the compressor load to increase operation voltage range.	
PID Control	Maximizes the working frequency before reaching the desired temperature, and, after that, constantly makes real-time adjustments to match room air temperature with the desired temperature.	
Turbo Cooling	The special control program allows the motor to work at a higher frequency. It enables users to enjoy a cool room within a much shorter time.	
Long Distance Airflow	The indoor unit get improved with better motor, optimized fan and air duct. It enables the air conditioner blows air as long as 20m.	
Strong Airflow	With improved fan and air duct, the air conditioner supplies up to 25% more air volume than the conventional.	
Warm Start	Blows no cold air when the unit is starting to work at heating mode, or change from cooling mode to heating mode.	
-15°C Heating	Provides powerful heating performance in cold winter with rotary compressor, etc.	
-10°C Cooling	Works at low ambient temperature with high frequency rotary compressor, optimized refrigerant system and special defrosting programme, etc.	
DC Motor	Ensures reliable operation with much higher energy saving and lower operation sound.	
DC Compressor	Reduces energy loss and maximize power input to achieve much higher energy efficiency.	
Smart Defrosting	Works only when necessary to reduce energy waste, and provide better experience by reducing defrosting time.	
Indoor 5-step Fan Speed	Works at powerful/high/middle/low/quiet speed to give users more choices in airflow control.	
Auto Vertical Airflow	Moves vertically and works with horizontal flaps to achieve various air angle.	
3-minute Protection	Helps compressor avoid unexpected damages to have longer life.	
Auto Restart	Returns operation to previous air conditioner settings after a sudden power break.	
Wide Voltage Operation	Enable interver AC to start working from 150V-264V	
89 Display	Shows clearly the real-time room temperature or desired temperature on the panel.	
Auto Mode	Helps air conditioner choose cooling or heating automatically based on desired temperature and ambient temperature.	
Integrated Structure	Combines the bottom base, drain pan and frame casing together to level up product reliability and lower vibration.	
Low Watt Standby	Lowers stand-by power consumption from 8W to about 1W by optimizing control programme.	
Outdoor 7-step Fan Speed	Makes adjustments according to the control of ambient sensor and tubing sensor to optimize heat exchange performance and improve energy efficiency.	
Coanda Plus Airflow	Makes the wind out of the air conditioner further, faster, and stronger, so that the cool air can be evenly delivered to every corner of the room.	
Whispering Air	Ensures your peace of mind with optimized fan, air duct and motor.	
Dry Function	Adjusts fan speed automatically according to room air temperature to achieve either mild dehumidification or strong dehumidification.	
3D Airflow	Delivers comfortable airflow to every corner of your room with the constant horizontal and vertical movements of airflow blades.	
Intelligent Air	Directs the airflow upwards at cooling mode, and downwards at heating mode to provide better air conditioning performance.	
Sleep Mode	Provides maximum comfort and energy saving during your good night's sleep.	
Positioning Specifications	Help fix the mounting plate and hang air conditioner at proper position.	
Extended Kickstand	Makes the installation easy with larger operation area to install and service.	
Easy Access Control Board	Simplifies dismounting and maintenance without disassembling casing.	
Wider Tubing Space	Saves installation time with larger operation space for piping and wiring.	
Easy Access Fan Motor	Simplifies dismounting and maintenance without disassembling evaporator.	
Self-diagnosis	Shows the error code on the LED display of the indoor unit to make the maintenance easier.	

2024

Suijinair

Fujinair & Suijinair

◆

◆

◆

◆

◆

◆

18K/24K

◆

◆

◆

◆

◆

◆

◆

◆

◆

◆

◆

◆

◆

◆

◆

◆

◆

◆

◆

◆

Fujinair & Suijinair

◆

◆

◆

◆































◆

◆

◆

◆

GLOSSARY OF ICONS

 1500W	POWER	 Filter Removable	FILTER REMOVABLE	 Antislip rubber foot	ANTISLIP RUBBER FOOT
 5L	CAPACITY IN LITERS	 180° Opening	OPENING 180°	 Cool touch handle	COOL TOUCH HANDLE
 Digital display	DIGITAL DISPLAY	 Detachable Drip Tray	DETACHABLE DRIP TRAY	 25 Speed Control	NUMBER OF SPEED CONTROL
 8 Presets	NUMBER OF PRESETS	 A+++	TYPE OF ENERGY	 DUAL resistance	TITANIUM COATING
 80° - 200°C	TEMPERATURE	 Self Cleaning Air ACONDICIONER	SELF CLEANING AIR ACONDICIONER	 22,5 cm Stainless steel foot	LONG STAINLESS STEEL FOOT
 Dishwasher safe	USE IN DISHWASHER	 3D Air Flow	3D AIR FLOW	 H10 Hepa Filter	FILTER TYPE
 1-6	NUMER OF POSITIONS	 Whispering Air	WHISPERING AIR	 Cordless	CORDLESS
 Number of slots	NUMBER OF SLOTS	 Anti-corrosion	ANTI-CORROSION	 2500 mAh 11.1 V Battery	BATTERY TYPE
 Defrost function toasters	DEFROST FUNCTION TOASTERS	 Number of decibels db	NUMBER OF DECIBELS	 Light type UVC light	LIGHT TYPE
 Crumbs collection tray	CRUMBS COLLECTION TRAY	 Remotecontrol	REMOTECONTROL	 Motorized Brush	BRUSH TYPE
 Heater function	HEATER FUNCTION	 WiFi control	WIFI CONTROL	 3 Accessories	NUMBER OF ACCESSORIES
 Digital control	DIGITAL CONTROL	 9000 BTU	BRITISH THERMAL UNIT	 4m Power Cord	LENGTH OF THE POWER CORD IN METERS
 Overheat Protection	OVERHEAT PROTECTION	 Heating DAC-30000PH	HEATING	 1.5L Clean water	CAPACITY OF THE CLEAN WATER TANK
 Boil dry Protection	BOIL DRY PROTECTION	 Automatic Control	AUTOMATIC CONTROL OF TEMPERATURE	 1.5L Dirty water	CAPACITY OF THE DIRTY WATER TANK
 stainless steel	STAINLESS STEEL MATERIAL	 3 in 1	3 INTERCHANGEABLE PLATES	 Viewing Window	VISIBLE WINDOW
 Cooking Light	LIGHT FOR VIEWING COOKING	 5 Levels POWER	LEVELS OF POWER	 FLEX Tube	FLEX TUBE
 Anti SPLASH	ANTI SPLASH SYSTEM	 Steel Grill Included	MICROWAVE ACCESSORY	 0.4L Dust Tank Capacity	DUST TANK CAPACITY

 PULSE switch	SPECIAL FUNCTION	 Child Lock	CHILD LOCK	 Telescopic Tube	TELESCOPIC TUBE
 TURBO Function	SPECIAL FUNCTION	 60 min Timer	TIMER MINUTES	 80 minutes Running Time	RUNNING TIME
 270° Viewing Window	SPECIAL VISION	 19:51 Digital Clock	TYPE OF CLOCK	 SUPER Quiet System®	SUPER QUIET SYSTEM
 Defrost	DEFROST FUNCTION AIR FRIER	 Express Cooking	ESTIMATED COOKING TIME	 SYNCRON Function	SYNCRONITATED FUNTION
 Autoclean	AUTO CLEAN FUNCTION	 Replaceable Filter	EASY FILTER CHANGE	 Dual Cooking	DUAL COOKING
 2 Cones	NUMBER OF THE CONES OF CITRUS JUICERS	 24H Timer	TIMER 24 HOURS	 GLASS Bowl	TYPRE OF MATERIAL
 Stainless Steel Cone	MATERIAL OF THE CONES OF CITRUS JUICERS	 2-4-8 HOURS Timer	TIMER 2-4-8 HOURS	 TURBO Function	TURBO FUNCTION
 Stainless Steel Filter	MATERIAL OF THE FILTERS OF CITRUS JUICERS	 4L Water Tank	LITERS OF WATER TANK	 Anti fingerprint	ANTI FINGERPRINT
 Anti - Drip	ANTI-DRIP SYSTEM	 40 minutes Running Time	TIME OF RUNNING		COMPLEMENTARY ACCESSORY
 Timer	TIMER FUNCTION	 MULTI Surface application	SURFACE APPLICATION		COMPLEMENTARY ACCESSORY
 Alarm Notification	ALARM FUNCTION	 HYBRID Cleaning System	SYSTEM OF CLEANNING	 Titanium	TITANIUM BLADES
 25.5 cm Glass Plate	TYPE OF DISH AND MEASUREMENT	 Ultra Fast Charging	ULTRA FAST CHARGING	 8 Satoku® Blades	QUANTITY OF SATOKU BLADES
 EASY To Clean	CLEANNING	 Hepa Filter	FILTER TYPE	 GLASS Jar	GLASS JAR
 25.5 cm Glass Plate	TYPE OF DISH AND MEASUREMENT	 Ultra Fast Charging	ULTRA FAST CHARGING		
 EASY To Clean	CLEANNING	 Hepa Filter	FILTER TYPE		
 TURBO Cooling	TURBO COOLING	 Nano-Aqua Sterilization	NANO-AQUA STERELIZATION		
 SMART Defrosting	SMART DEFROSTING	 AIRFLOW distance	AIR FLOW DISTANCE		

aiwa[®]

AIWA CO., LTD. TOKYO, JAPAN

www.aiwa-industries.com