

# HARU AIR SERIES



## FUNCTIONS

**Turbo Cooling:** Provides rapid cooling to quickly lower room temperature, ideal for hot summer days.

**WiFi Control:** Manage your AC unit from anywhere using a smartphone app, offering convenience and flexibility.

**+8°C Heating:** Keeps rooms warm during cold weather by maintaining a minimal heating temperature.

**Sleep Mode:** Adjusts settings to create a comfortable sleeping environment, promoting better sleep quality.

**Wide Voltage Operation:** Ensures reliable performance in areas with unstable voltage, protecting the unit and maintaining efficiency.

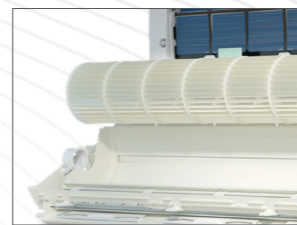
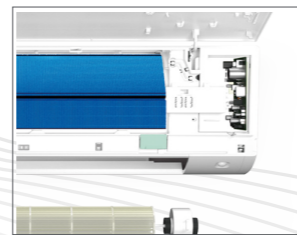

## HIGHLIGHTS

**Energy Efficiency:** High SEER/EER ratings for cost-effective cooling and heating, making it an eco-friendly choice that reduces energy bills.

**Quiet Operation:** Low noise levels ensure a peaceful environment, perfect for bedrooms, study rooms, and offices.

**Wide Operating Limits:** Performs efficiently across a broad range of temperatures, providing reliable comfort in all seasons.

**Advanced Filtration:** HEPA and stainless steel filters improve indoor air quality by removing dust, allergens, and other pollutants.

**Smart Features:** Includes WiFi control for remote operation and Turbo Cooling for rapid temperature adjustments.

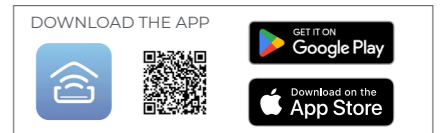

# HARU AIR

## HARU AIR 24

AIR CONDITIONING ACD-24000

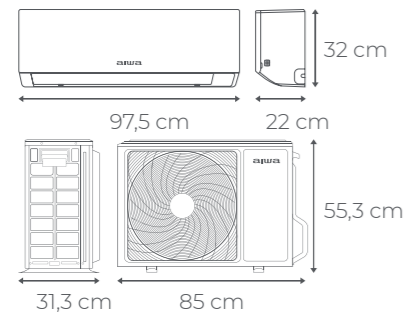

Cooling Energy Efficiency (SEER/EER)	6.70/3.10
Cooling Energy Class	A++
Heating Energy Efficiency (SCOP/COP Mild)	4.00/3.61
Heating Energy Class (Mild/Warm/Cold)	A+/A+++/-
Indoor Cooling / Heating Sound Power Level (Hi)	64 db

Best for large areas up to 42 square meters. Suitable for expansive living rooms or large office environments, ensuring comprehensive temperature control.

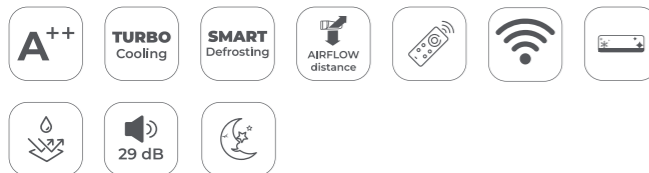

MODEL: ACD-24000		
PRODUCT CODE	BAR CODE	MASTER BOX
9521004 (I)	8435256900590	1
9521004 (E)	8435256900651	1

## HARU AIR 18

AIR CONDITIONING ACD-18000

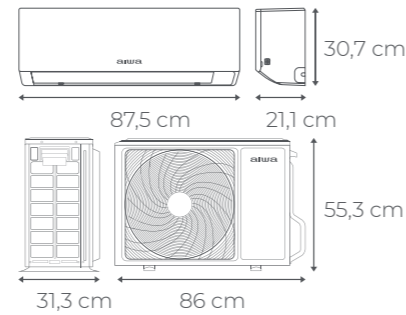

Cooling Energy Efficiency (SEER/EER)	6.30/2.81
Cooling Energy Class	A++
Heating Energy Efficiency (SCOP/COP Mild)	4.00/3.60
Heating Energy Class (Mild/Warm/Cold)	A+/A+++/-
Indoor Cooling / Heating Sound Power Level (Hi)	60 db

Perfect for larger rooms up to 33 square meters. Ideal for open-plan living areas or larger office spaces, providing uniform comfort.

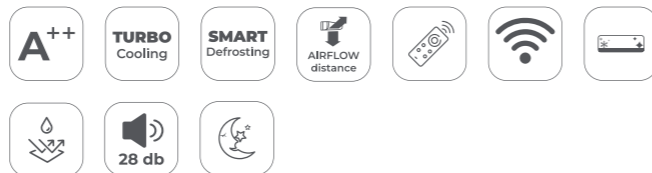

MODEL: ACD-18000		
PRODUCT CODE	BAR CODE	MASTER BOX
9521003 (I)	8435256900583	1
9521003 (E)	8435256900644	1

## HARU AIR 12

AIR CONDITIONING ACD-12000

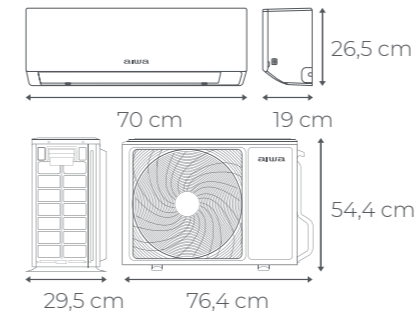

Cooling Energy Efficiency (SEER/EER)	6.10/2.81
Cooling Energy Class	A++
Heating Energy Efficiency (SCOP/COP Mild)	4.00/3.21
Heating Energy Class (Mild/Warm/Cold)	A+/A+++/-
Indoor Cooling / Heating Sound Power Level (Hi)	57 db

Suitable for medium-sized rooms up to 23 square meters. Great for living rooms or larger bedrooms, offering efficient cooling and heating.

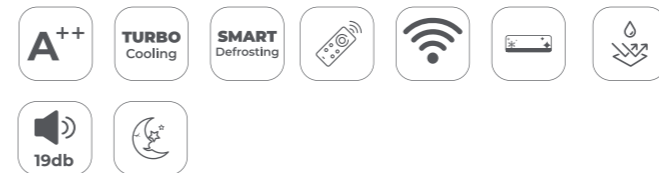

MODEL: ACD-12000		
PRODUCT CODE	BAR CODE	MASTER BOX
9521002 (I)	8435256900613	1
9521002 (E)	8435256900637	1

## HARU AIR 9

AIR CONDITIONING ACD-9000

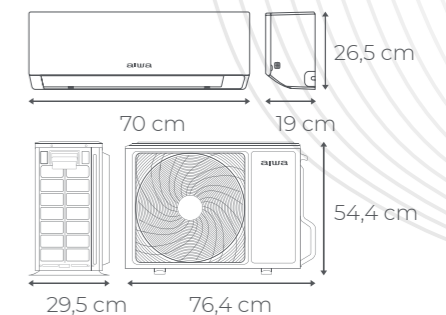

Cooling Energy Efficiency (SEER/EER)	6.1/3.01
Cooling Energy Class	A++
Heating Energy Efficiency (SCOP/COP Mild)	4/3.21
Heating Energy Class (Mild/Warm/Cold)	A+/A+++/-
Indoor Cooling / Heating Sound Power Level (Hi)	54 db

Ideal for small rooms up to 14 square meters. Perfect for bedrooms or small offices, ensuring a cool, quiet environment for restful sleep or focused work.

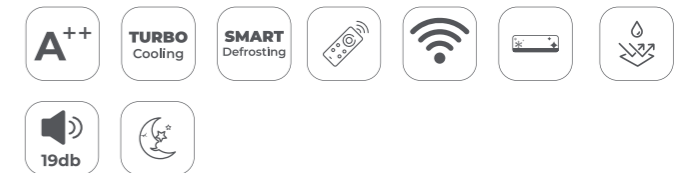

MODEL: ACD-9000		
PRODUCT CODE	BAR CODE	MASTER BOX
9521001 (I)	8435256900606	1
9521001 (E)	8435256900620	1

MODEL		HARUAIR 9 FUJINAIR 9 SUJINAIR 9	HARUAIR 12 FUJINAIR 12 SUJINAIR 12	HARUAIR 18 FUJINAIR 18 SUJINAIR 18	HARUAIR 24 FUJINAIR 24 SUJINAIR 24		
	Nominal (Min-Max)						
	kW	2.5(0.8-3.0)	3.20(0.80-3.50)	4.80(1.30-5.40)	6.20(1.30-7.40)		
Energy Efficiency	SEER/EER	6.1/3.01	6.10/2.81	6.30/2.81	6.70/3.10		
Energy Class		A++	A++	A++	A++		
Pdesign Capacity							
	kW	2.5	3.20	4.80	6.20		
Power Input	Nominal (Min-Max)						
	kW	0.83(0.3-1.2)	1.138(0.30-1.50)	1.708(0.40-1.90)	2.000(0.40-2.20)		
Annual Energy Consumption							
	kWh/a	143	184	267	324		
Operating Limits	Min-Max						
	°C	-10-43°C(out)	-10-43°C(out)	-15-43°C(out)	-15-43°C(out)		
HEATING	Capacity	Nominal (Min-Max)					
		Btu/h	9550(2730-11260)	11600(2730-12280)	16380(4430-18420)	21500(4770-25590)	
	Capacity	Nominal (Min-Max)					
		kW	2.8(0.8-3.3)	3.40(0.80-4.00)	4.80(1.30-5.40)	6.30(1.40-7.50)	
	Energy Efficiency	SCOP/COP (Mild)	4/3.21	4.00/3.21	4.00/3.60	4.00/3.61	
		SCOP (Warm/Cold)	4.60/-	4.60/-	5.10/-	5.10/-	
	Energy Class	Mild/Warm/Cold	A+/A++/-	A+/A++/-	A+/A++/-	A+/A++/-	
	Pdesign Capacity (-10°C)						
		kW	2.1	2.60	3.60	4.60	
Power Input	Nominal (Min-Max)						
	kW	0.872(0.3-1.2)	1.059(0.30-1.50)	1.333(0.40-1.90)	1.745(0.60-2.30)		
Annual Energy Consumption							
	kWh/a	735	910	1260	1610		
Operating Limits							
	°C	-15-24°C(out)	-15-24°C(out)	-15-24°C(out)	-15-24°C(out)		
Power Supply	Ph/V/Hz	1/220-240/50	1/220-240/50	1/220-240/50	1/220-240/50		
	Position	indoor	indoor	outdoor	outdoor		
INDOOR	Net Dimension	W/D/H	705/193/265	705/193/265	875/212/304	975/222/318	
	Package Dimension	W/D/H	772/325/263	772/325/263	945/390/296	1050/397/301	
	Net/Shipping Weight		7.5/8.8	7.8/9.2	10.0/12.0	11.6/14.4	
	Air Flow (Cooling/Heating)	Max	520/520	520/520	770/810	1100/1000	
	Sound Power Level	Cooling (Hi)	54	57	60	64	
		Heating (Hi)	54	57	60	64	
	Sound Pressure Level	Cooling (Hi/Mid/Lo/So)	38/34/30/18	39/35/31/19	44/40/35/28	47/45/37/29	
		Heating (Hi/Mid/Lo/So)	38/34/30/18	39/35/31/19	44/40/35/28	47/45/37/29	
	Moisture Removal		10-3m³/h	1.2	1.4	2	2.8
OUTDOOR	Compressor		HIGHLY	HIGHLY	SANYO	HIGHLY	
	Net Dimension	W/D/H	700/245/544	700/245/544	800/275/553	800/275/553	
	Package Dimension	W/D/H	819/320/585	819/320/585	902/375/607	902/375/607	
	Net/Shipping Weight		21.8/23.9	22.9/25	29.2/32.1	32.7/36.5	
	Air Flow (Cooling/Heating)	Max	2100/2100	2100/2100	2200/2200	2500/2500	
	Sound Power Level	Hi	62	63	65	68	
	Sound Pressure Level	Hi	50	50	54	57	
	Running Current	Max	A	5.3	6.5	8.6	10.5
	Refrigerant Type	R410a/R32	R32	R32	R32	R32	
	Refrigerant Charge	R410a/R32	g	500	550	780	900
	Refrigerant Pipe	Liquid Side Diameter	mm	6.35	6.35	6.35	6.35
		Gas Side Diameter	mm	9.52	9.52	12.7	12.7
		Max Pipe Length/Height	m	20/10	20/10	20/15	25/15
		Max Pipe Length without Additional Charge	m	5	5	7	7
	Additional Charge	g/m	20	20	20	20	

FUNCTIONS	INTRODUCTION	2024
<b>TOSEI AQUA Sterilization</b>	Ionizes the air and releases positive and negative ions to sterilize the air with efficiency up to 97.5%.	Suijinair
<b>Triple filter tech</b>	Utilizes mixed powerful filter plus electronic filter, combining to prevent the air conditioner from harmful micro-particles including dust, virus and bacteria	Fujinair & Suijinair
<b>Anti-Corrosion</b>	Helps condensate flow smoothly via its hydrophilic and anti-corrosive properties.	◆
<b>Self Clean</b>	Freezes the evaporator with moisture in the air, and then removes away dirt in melting, ensuring clean air out of the air conditioner.	◆
<b>WiFi Control</b>	Download the Tuya Intelligent Air App to an Apple or Android smart device, and link the equipment to the smart device for system control from whenever and wherever you want.	◆
<b>A-PAM Control</b>	Automatically adjusts DC bus voltage in accordance with the compressor load to increase operation voltage range.	◆
<b>PID Control</b>	Maximizes the working frequency before reaching the desired temperature, and, after that, constantly makes real-time adjustments to match room air temperature with the desired temperature.	◆
<b>Turbo Cooling</b>	The special control program allows the motor to work at a higher frequency. It enables users to enjoy a cool room within a much shorter time.	◆
<b>Long Distance Airflow</b>	The indoor unit get improved with better motor, optimized fan and air duct. It enables the air conditioner blows air as long as 20m.	18K/24K
<b>Strong Airflow</b>	With improved fan and air duct, the air conditioner supplies up to 25% more air volume than the conventional.	◆
<b>Warm Start</b>	Blows no cold air when the unit is starting to work at heating mode, or change from cooling mode to heating mode.	◆
<b>-15°C Heating</b>	Provides powerful heating performance in cold winter with rotary compressor, etc.	◆
<b>-10°C Cooling</b>	Works at low ambient temperature with high frequency rotary compressor, optimized refrigerant system and special defrosting programme, etc.	◆
<b>DC Motor</b>	Ensures reliable operation with much higher energy saving and lower operation sound.	◆
<b>DC Compressor</b>	Reduces energy loss and maximize power input to achieve much higher energy efficiency.	◆
<b>Smart Defrosting</b>	Works only when necessary to reduce energy waste, and provide better experience by reducing defrosting time.	◆
<b>Indoor 5-step Fan Speed</b>	Works at powerful/high/middle/low/quiet speed to give users more choices in airflow control.	◆
<b>Auto Vertical Airflow</b>	Moves vertically and works with horizontal flaps to achieve various air angle.	◆
<b>3-minute Protection</b>	Helps compressor avoid unexpected damages to have longer life.	◆
<b>Auto Restart</b>	Returns operation to previous air conditioner settings after a sudden power break.	◆
<b>Wide Voltage Operation</b>	Enable interver AC to start working from 150V-264V	◆
<b>89 Display</b>	Shows clearly the real-time room temperature or desired temperature on the panel.	◆
<b>Auto Mode</b>	Helps air conditioner choose cooling or heating automatically based on desired temperature and ambient temperature.	◆
<b>Integrated Structure</b>	Combines the bottom base, drain pan and frame casing together to level up product reliability and lower vibration.	◆
<b>Low Watt Standby</b>	Lowers stand-by power consumption from 8W to about 1W by optimizing control programme.	◆
<b>Outdoor 7-step Fan Speed</b>	Makes adjustments according to the control of ambient sensor and tubing sensor to optimize heat exchange performance and improve energy efficiency.	◆
<b>Coanda Plus Airflow</b>	Makes the wind out of the air conditioner further, faster, and stronger, so that the cool air can be evenly delivered to every corner of the room.	◆
<b>Whispering Air</b>	Ensures your peace of mind with optimized fan, air duct and motor.	◆
<b>Dry Function</b>	Adjusts fan speed automatically according to room air temperature to achieve either mild dehumidification or strong dehumidification.	◆
<b>3D Airflow</b>	Delivers comfortable airflow to every corner of your room with the constant horizontal and vertical movements of airflow blades.	Fujinair & Suijinair
<b>Intelligent Air</b>	Directs the airflow upwards at cooling mode, and downwards at heating mode to provide better air conditioning performance.	◆
<b>Sleep Mode</b>	Provides maximum comfort and energy saving during your good night's sleep.	◆
<b>Positioning Specifications</b>	Help fix the mounting plate and hang air conditioner at proper position.	◆
<b>Extended Kickstand</b>	Makes the installation easy with larger operation area to install and service.	◆
<b>Easy Access Control Board</b>	Simplifies dismounting and maintenance without disassembling casing.	◆
<b>Wider Tubing Space</b>	Saves installation time with larger operation space for piping and wiring.	◆
<b>Easy Access Fan Motor</b>	Simplifies dismounting and maintenance without disassembling evaporator.	◆
<b>Self-diagnosis</b>	Shows the error code on the LED display of the indoor unit to make the maintenance easier.	◆

## SPECIFICATIONS

### TYPE

Category:	<b>AIR TREATMENT</b>	Product Code:	<b>9521003</b>
Product Family:	<b>Air Conditioning</b>	EAN Code Split (I):	<b>8435256900583</b>
Type:	<b>HARUAIR Series</b>	EAN Code Outdoor machine (E):	<b>8435256900644</b>

### AESTHETICS

Colour:	<b>WHITE</b>	Aesthetic:	<b>HARUAIR</b>
Finishing:	<b>Satin</b>	Body material:	<b>Plastic</b>

### PROGRAMME / FUNCTIONS

TOSEI AQUA Sterilization:	<b>No</b>	WiFi Control:	<b>Yes</b>
Long Distance Airflow:	<b>Yes</b>	Turbo Cooling:	<b>Yes</b>
3D Airflow:	<b>No</b>	Strong Airflow:	<b>Yes</b>
Triple filter tech:	<b>No</b>	Warm Start:	<b>Yes</b>
Anti-Corrosion:	<b>Yes</b>	Smart Defrosting:	<b>Yes</b>

### CONTROLS

REMOTE CONTROL:	<b>Yes</b>	Buttons material:	<b>Ruber</b>
Pulsante ON/OFF:	<b>Yes</b>		

### TECHNICAL FEATURES COOLING

Capacity Nominal (Min-Max)BTU/H:	<b>16380 (4430-18420)</b>	P. design Capacity:	<b>4,8 kw</b>
Caapcity Nominal (Min-Max)KW:	<b>16380 (4430-18420)</b>	P. Input Nominal (Min-Max):	<b>1,708 (0,40-1,90) kw</b>
SEER/EER:	<b>6,30 / 2,81</b>	Annual Energy Consumption:	<b>267 kw</b>
Energy Class:	<b>A+</b>	Operating Limits Min-Max:	<b>-15-43°C(out)</b>

### TECHNICAL FEATURES HEATING

Cap. Nominal (Min-Max)BTU/H:	<b>16380 (4430-18420)</b>	P. design Capacity (-10°C):	<b>3,6 kw</b>
Cap. Nominal (Min-Max)KW:	<b>4,80 (1,30-5,40)</b>	P. Input Nominal (Min-Max):	<b>1,333 (0,40-1,90) kw</b>
SCOP/COP (Mild):	<b>4,00 / 3,60</b>	Annual Energy Consumption:	<b>1260 kw</b>
SCOP (Warm/Cold):	<b>5,10 / -</b>	Operating Limits:	<b>-15-24°C(out)</b>
Energy Class Mild/Warm/Cold:	<b>A+ / A+++ / -</b>	P. Supply Ph/V/Hz (position):	<b>1/220-240/50 (outdoor)</b>

### TECNICAL FEATURES INDOOR

Air Flow (Cooling/Heating):	<b>770 / 810 m³/h</b>	Sound Cooling (Hi/Mid/Lo/So):	<b>44/40/35/28 dB</b>
Sound P. Cooling:	<b>60 dB</b>	Sound Heating (Hi/Mid/Lo/So):	<b>44/40/35/28 dB</b>
Sound P. Heating:	<b>60 dB</b>	Moisture Removal 10-3m³/h:	<b>2</b>

### TECNICAL FEATURES OUTDOOR

Air Flow (Cooling/Heating):	<b>2200 / 2200 m³/h</b>	Refrigerant Pipe Diameter:	<b>6,35 mm</b>
Sound P. Cooling:	<b>65 dB</b>	Gas Side Diameter:	<b>12,7 mm</b>
Sound P. Heating:	<b>54 dB</b>	Max Pipe Length/Height:	<b>20/15 m</b>
Running Current Max:	<b>8,6</b>	Max Pipe Length Charge:	<b>7 m</b>
Refrigerant Type:	<b>R32</b>	Additional Charge:	<b>20 g/m</b>
Refrigerant Charge:	<b>780 gr</b>	Compressor:	<b>SANYO</b>

### ELECTRICAL CONNECTION

Rating:	<b>220-240 V~</b>	Power cooling:	<b>4,8 kw</b>
Frequency:	<b>50 Hz</b>	Power heating:	<b>6,3 kw</b>

### LOGISTIC INFORMATION INDOOR

Net Dimension W/D/H:	<b>875/212/304 mm</b>	Net/Shipping Weight:	<b>10,0 / 12,0 kg</b>
Package Dimension W/D/H:	<b>945/390/296 mm</b>	Mater Box:	<b>1</b>

### LOGISTIC INFORMATION OUTDOOR

Net Dimension W/D/H:	<b>800/275/553 mm</b>	Net/Shipping Weight:	<b>29,2 / 32,1 kg</b>
Package Dimension W/D/H:	<b>902/375/607 mm</b>	Mater Box:	<b>1</b>