

HAND BLENDER

KITCHEN SOLUTIONS

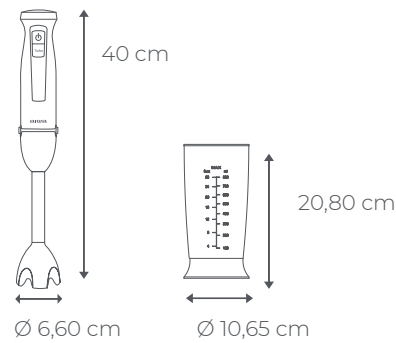

Power	1200 W
Speed control	40 + Turbo
Blades type	6 Titanium Satoku®
Rod	Stainless Steel
Accessories	Baker with lid
BPA Free	



KENKIRI 1200

HAND BLENDER ABL-1200

- **Power:** 1200W motor, balancing power and energy efficiency.
 - **Speed Settings:** 40 speeds plus Turbo, catering to a range of textures.
 - **Blades:** 6 Titanium Satoku® blades for sustained sharpness and performance.
 - **Accessories:** Includes an 800 ml measuring cup with lid.
 - **Design:** Streamlined and robust, with a focus on performance.
 - **Rod:** Stainless steel rod designed to withstand daily use.
- Antisplash proof.**

POWER AND PERFORMANCE IN EVERY BLEND

Balanced Power: The 1200W motor provides a perfect blend of energy efficiency and blending power for everyday kitchen tasks.

Tailored Textures: Multiple speed settings and Turbo give users the ability to achieve the desired consistency every time.

Functional Design: A focus on straightforward functionality, this model combines professional blending capability with ease of use.



1200W	40 Speed Control	Splash-Proof	22.5 cm Stainless steel foot	1 Accessories	TURBO Function
BPA Free	Titanium	6 Satoku® Blades			

MODEL: ABL-1200		
PRODUCT CODE	BAR CODE	MASTER BOX
9181005	8435256810097	6

KENKIRI 1200

HAND BLENDER ABL-1200

aiwa®

SPECIFICATIONS

TYPE			
Category:	KITCHEN SOLUTIONS	Product Code:	9181005
Product Family:	Food Preparation	EAN Code:	8435256810097
Type:	Hand Blenders	Motor power:	1200 W

AESTHETICS			
Colour:	Black	Blades material:	6 Titanium Kenkiri®
Finishing:	Soft touch	Back color handle:	Black
Aesthetic:	KENKIRI	Back handle material:	Inox
Body material:	Inox	Cable color:	Black
Blending arm material:	Stainless Steel		

PROGRAMME / FUNCTIONS			
Variable speed:	Yes	Speed control:	40
Turbo function:	Yes		

CONTROLS			
Control Panel:	Buttons, Knob	Buttons material:	Plastic
Button ON/OFF:	Yes	Buttons ring color:	Inox AIWA
Buttons color:	Black	Buttons ring material:	Inox

TECHNICAL FEATURES			
Cut system:	Flowblend	Built-in cord wrap:	Yes
Accessories fixing:	Buttons	Hand blender dimensions:	6,6x6,6x40 cm
Anti slip handle:	Yes		

ELECTRICAL CONNECTION			
Rating:	220-240 V~	Power:	1200 W
Frequency:	50/60 Hz	Cord lenght:	1.5 m

LOGISTIC INFORMATION			
Product lenght:	66 mm	Gross weight:	2 kg
Product width:	66 mm	Net weight:	1,5 kg
Product height:	400 mm	Type of packaging:	Cartone
Widht of the packed product:	187 mm	Carton box height:	42 cm
Depth of packaged product:	135 mm	Carton box dimensions:	420x389x255 mm
Height of the packed product:	240 mm	Master BOX:	6