

HAND BLENDER

KITCHEN SOLUTIONS

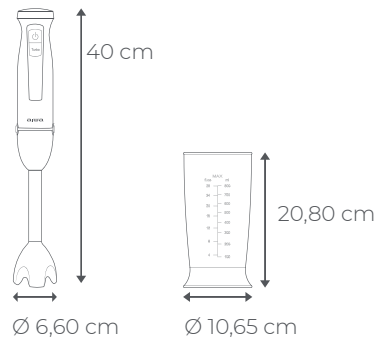

Power	1500 W
Speed control	40 + Turbo
Blades type	6 Titanium Satoku®
Rod	Stainless Steel
Accessories	1
BPA Free	



KENKIRI 1500

HAND BLENDER ABL-1500

- **Power:** 1500W motor for high-powered blending tasks.
- **Speed Settings:** 40 speed options plus a Turbo feature for precise control.
- **Blades:** 6 Titanium Satoku® blades for superior cutting and longevity.
- **Accessories:** Includes an 800 ml measuring cup with lid for accurate ingredient portions.
- **Construction:** Durable stainless steel (SS) rod for long-lasting use.
- **Design:** Professional build quality suitable for both home and commercial kitchens. **Antisplash proof.**

ULTIMATE PRECISION AND POWER FOR EVERY BLEND

Powerful Precision: With a robust 1500W motor and 40 speed settings plus Turbo, the KENKIRI 1500 delivers unmatched precision for any blending task.

Titanium Edge: The six titanium blades Satoku® ensure long-lasting sharpness and superior performance in cutting through tough ingredients.

Quality Build: The durable stainless steel rod is crafted for longevity, reflecting the blender's high-quality construction.



MODEL: ABL-1500		
PRODUCT CODE	BAR CODE	MASTER BOX
9181001	8435256810110	6

KENKIRI 1500

HAND BLENDER ABL-1500

aiwa®

SPECIFICATIONS

TYPE			
Category:	KITCHEN SOLUTIONS	Product Code:	9181001
Product Family:	Food Preparation	EAN Code:	8435256810110
Type:	Hand Blenders	Motor power:	1500 W

AESTHETICS			
Colour:	Black	Blades material:	6 Titanium Kenkiri®
Finishing:	Soft touch	Back color handle:	Black
Aesthetic:	KENKIRI	Back handle material:	Inox
Body material:	Inox	Cable color:	Black
Blending arm material:	Stainless Steel		

PROGRAMME / FUNCTIONS			
Variable speed:	Yes	Speed control:	40
Turbo function:	Yes		

CONTROLS			
Control Panel:	Buttons, Knob	Buttons material:	Plastic
Button ON/OFF:	Yes	Buttons ring color:	Inox AIWA
Buttons color:	Black	Buttons ring material:	Inox

TECHNICAL FEATURES			
Cut system:	Flowblend	Built-in cord wrap:	Yes
Accessories fixing:	Buttons	Hand blender dimensions:	6,6x6,6x40 cm
Anti slip handle:	Yes		

ELECTRICAL CONNECTION			
Rating:	220-240 V~	Power:	1500 W
Frequency:	50/60 Hz	Cord lenght:	1.5 m

LOGISTIC INFORMATION			
Product lenght:	66 mm	Gross weight:	2 kg
Product width:	66 mm	Net weight:	1,5 kg
Product height:	400 mm	Type of packaging:	Cartone
Widht of the packed product:	187 mm	Carton box height:	42 cm
Depth of packaged product:	135 mm	Carton box dimensions:	420x389x255 mm
Height of the packed product:	240 mm	Master BOX:	6