

PERSONAL BLENDER  
KITCHEN SOLUTIONS

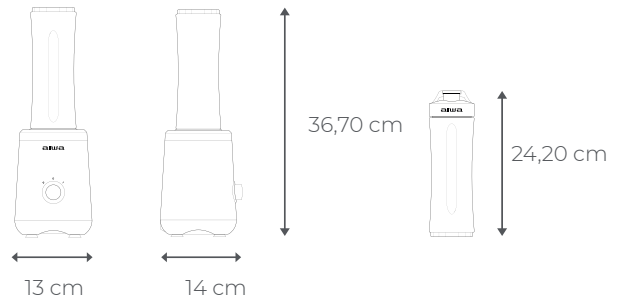

Power	500 W
Volume Jar	2 x 600 ml
Jar material	Tritan®
Program	1 + Pulse
Blades Satoku® Patented	6



SABERU 600

PERSONAL BLENDER ATB-600

- **550W Power:** Sufficient for personal blending needs with efficient energy usage.
- **Dual 450ml Tritan® Jars:** Perfect for on-the-go lifestyles, providing durability and ease of cleaning.
- **Single Programme:** Streamlined operation for quick and effortless blending.
- **Four Satoku® Blades:** Precision-engineered for a smooth blend every time.
- **Compact Design:** Ideal for small countertops and space-saving storage.
- **Easy Maintenance:** Designed with simplicity in mind for hassle-free upkeep.



<b>500W</b>	<b>0,6L</b>	<b>2</b> Takeaway Bottles	<b>TRITAN®</b> Jar	<b>PULSE</b> switch	<b>4 Satoku®</b> Blades
<b>BPA Free</b>	<b>Anti fingerprint</b>				

**EFFICIENT POWER, CONVENIENT PORTABILITY, AND SIMPLE EFFECTIVENESS**

**Efficient and Powerful:** The SABERU 600 is equipped with a 550W motor, providing ample power for a wide range of personal blending tasks while ensuring energy-efficient operation.

**Convenient and Portable:** With dual 450ml Tritan® jars, this blender is designed for active, on-the-go lifestyles. The durable and easy-to-clean jars make it perfect for those who want their nutritious blends anywhere, anytime.

**Simple and Effective:** The single programme feature offers a user-friendly experience, ensuring quick and effortless blending with just the touch of a button. Coupled with four precision Satoku® blades, the SABERU 600 delivers consistently smooth results, no matter the ingredients.

MODEL: ATB-600		
PRODUCT CODE	BAR CODE	MASTER BOX
9183002	8435256810462	8

# SABERU 600

aiwa®

PERSONAL BLENDER ATB-600

## SPECIFICATIONS

TYPE			
Category:	<b>KITCHEN SOLUTIONS</b>	Product Code:	<b>9183002</b>
Product Family:	<b>Food preparation</b>	EAN Code:	<b>8435256810462</b>
Type:	<b>Personal Blender</b>	Motor power:	<b>500 W</b>

AESTHETICS			
Colour:	<b>Senshirubā INOX</b>	Jar material:	<b>Tritan®</b>
Finishing:	<b>Matte</b>	Blades material:	<b>Blades Satoku® Patented</b>
Aesthetic:	<b>SABERU</b>	Cable color:	<b>Black</b>
Body material:	<b>Inox / Tritan®</b>		

PROGRAMME / FUNCTIONS			
Pre-sets:	<b>3</b>	Pulse switch:	<b>Yes</b>
Speeds:	<b>2</b>	Ice crush:	<b>Yes</b>
Smoothie:	<b>Yes</b>	Autoclean:	<b>No</b>

CONTROLS			
Type of controls:	<b>Buttons, control knobs</b>	Buttons material:	<b>Plastic</b>

TECHNICAL FEATURES			
Volume Jar:	<b>2 x 600 ml</b>	Blade group removable:	<b>Yes</b>
Motor thermal protection:	<b>Yes</b>	Measuring cup/lid:	<b>Yes</b>
Safety motor block:	<b>Yes</b>	Antislip base:	<b>Yes</b>
Blades:	<b>6</b>	Built-in cord wrap:	<b>Yes</b>

ELECTRICAL CONNECTION			
Rating:	<b>220-240 V ~</b>	Power:	<b>500 W</b>
Frequency:	<b>50/60 Hz</b>	Cord lenght:	<b>0,75 m</b>

LOGISTIC INFORMATION			
Product lenght:	<b>130 mm</b>	Gross weight:	<b>1.5 Kg</b>
Product width:	<b>140 mm</b>	Net weight:	<b>1,3 Kg</b>
Product height:	<b>242 mm</b>	Type of packaging:	<b>Carton</b>
Widht of the packed product:	<b>263 mm</b>	Carton box height:	<b>38 cm</b>
Depth of packaged product:	<b>177 mm</b>	Carton box dimensions:	<b>384x312x380 mm</b>
Height of the packed product:	<b>260 mm</b>	Master BOX:	<b>6</b>