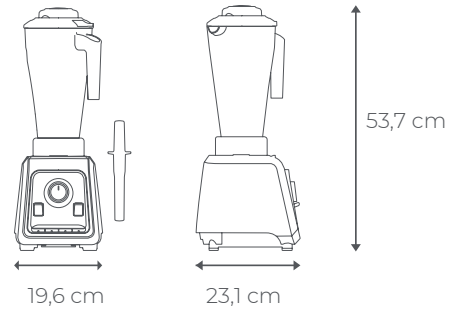

TABLE BLENDER  
KITCHEN SOLUTIONS



Power	1500 W
Volume Jar	2 L
Programme	4 + Pulse
Speed control	Yes
Jar material	Tritan®
Blades Satoku® Patented	6
Autoclean	Yes



SABERU PRO

TABLE BLENDER ATB-3000

- **1500W Power:** Balances efficiency and strength for professional environments.
- **2L TRITAN Jar:** Large and robust, ideal for heavy use without compromising on quality.
- **Four Programmes + Pulse:** Offers versatility for a wide array of blending techniques.
- **Six Satoku® Blades:** Ensures unparalleled precision and longevity.
- **Ergonomic and Safe Design:** Designed for frequent use with user safety in mind.
- **Noise Reduction Technology:** Engineered for quieter operation in professional settings.

USER-CENTRIC DESIGN: SABERU PRO

**Substantial and Sturdy Jar:** Equipped with a 2-liter TRITAN jar, this blender is designed to handle heavy usage without sacrificing quality, ensuring durability and reliability in fast-paced settings.

**Versatile Blending Options:** With four distinct programs plus a pulse feature, the SABERU PRO can effortlessly adapt to a broad range of blending techniques, from delicate mixes to robust purees.

**Advanced Blade System:** The six Satoku® Blades are designed not only for their precision cutting ability but also for their lasting sharpness, providing consistent results and enduring performance.

**Quiet Operation:** Innovative noise reduction technology minimizes sound output, a crucial feature for maintaining a more pleasant and professional atmosphere in open-kitchen layouts and small spaces.

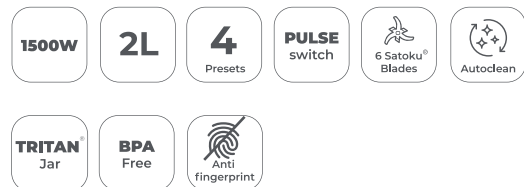

MODEL: ATB-3000		
PRODUCT CODE	BAR CODE	MASTER BOX
9182004	8435256810455	2

## SPECIFICATIONS

TYPE			
Category:	<b>KITCHEN SOLUTIONS</b>	Product Code:	<b>9182004</b>
Product Family:	<b>Food preparation</b>	EAN Code:	<b>8435256810455</b>
Type:	<b>Table Blender</b>	Motor power:	<b>1500 W</b>

AESTHETICS			
Colour:	<b>Senshirubā INOX</b>	Jar material:	<b>Tritan®</b>
Finishing:	<b>Matte</b>	Lid material:	<b>Tritan® / plastic BPA free</b>
Aesthetic:	<b>SABERU</b>	Blades material:	<b>Blades Satoku® Patented</b>
Body material:	<b>Inox / plastic BPA free</b>	Cable color:	<b>Black</b>

PROGRAMME / FUNCTIONS			
Pre-sets:	<b>4</b>	Pulse switch:	<b>Yes</b>
Speeds:	<b>4</b>	Ice crush:	<b>Yes</b>
Smoothie:	<b>Yes</b>	Autoclean:	<b>Yes</b>

CONTROLS			
Type of controls:	<b>Buttons, control knobs</b>	Buttons material:	<b>Plastic</b>
Control knobs material:	<b>Plastic</b>		

TECHNICAL FEATURES			
Volume Jar:	<b>2 L</b>	Blade group removable:	<b>Yes</b>
Motor thermal protection:	<b>Yes</b>	Measuring cup/lid:	<b>Yes</b>
Safety motor block:	<b>Yes</b>	Antislip base:	<b>Yes</b>
Blades:	<b>6</b>	Built-in cord wrap:	<b>Yes</b>

ELECTRICAL CONNECTION			
Rating:	<b>220-240 V ~</b>	Power:	<b>1500 W</b>
Frequency:	<b>50/60 Hz</b>	Cord length:	<b>0,75 m</b>

LOGISTIC INFORMATION			
Product length:	<b>196 mm</b>	Gross weight:	<b>2,92 kg</b>
Product width:	<b>231 mm</b>	Net weight:	<b>2,64 kg</b>
Product height:	<b>537 mm</b>	Type of packaging:	<b>Carton</b>
Width of the packed product:	<b>408 mm</b>	Carton box height:	<b>40 cm</b>
Depth of packaged product:	<b>277 mm</b>	Carton box dimensions:	<b>570x421x400 mm</b>
Height of the packed product:	<b>375 mm</b>	Master BOX:	<b>2</b>