

VACUUM CLEANER

HOME CARE



ZENKAI SUI EVO 4

VACUUM CLEANER AVC-610

- **Battery Info:** 29.6V Lithium-ion 3000mAh, 7 cells
- **DC Motor Power:** 500W Brushless motor (BLDC)
- **Vacuum Power:** High speed: 32Kpa
- **Suction Power:** 120AW
- **Noise Level:** ≤82 dB
- **Air Inlet Filter:** HEPA + stainless steel filter
- **Dust Tank Capacity:** 600ml
- **Accessories:** Wall bracket, self-standing electric brush (S40), adapter, conductive aluminum tube, long flat crevice nozzle
- **Self-Standing Electric Brush:** YES
- **Removable Battery Pack:** YES
- **IA Zenkaisui Mode:** Allows changing power device when not needed to improve working time
- **Motorized Roller with LED Illumination:** YES, for hard floors and carpet

EFFICIENT CLEANING COMPANION FOR EVERY HOME

Battery Life: Features a robust 29.6V 3000mAh Lithium-ion battery, providing up to 70 minutes of continuous use, ideal for extended cleaning sessions.

Motor Efficiency: Comes with a 500W brushless motor that balances power and energy efficiency, offering powerful suction while maintaining quieter operations.

Suction Capability: Achieves strong suction at 32Kpa and 120AW, efficiently removing dust, debris, and allergens.

Filtration System: Utilizes a HEPA and stainless steel filter combo to capture fine particles and clean expelled air.

Dust Tank Capacity: Includes a 600ml dust tank to minimize emptying interruptions.

Charging and Storage: Provides convenient storage with a wall bracket and features a self-standing electric brush with a 3-3,5 hour fast charging time.

Power	500W Brushless motor (BLDC)
Suction	120 AW
Ultra fast Charging time	3-3,5 h
IA Zenkaisui mode	Yes
Speeds	3 (min, max, auto)
Led Screen	Yes
Running time	70 min

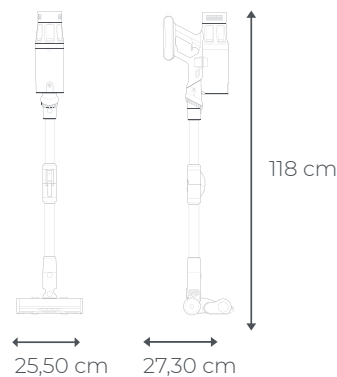

MODEL: AVC-610		
PRODUCT CODE	BAR CODE	MASTER BOX
9361002	8435256810479	2

SPECIFICATIONS

TYPE			
Category:	HOME CARE	Product Code:	9361002
Product Family:	Cleaner	EAN Code:	8435256810479
Type:	Vacuum cleaner	Motor power:	500W

AESTHETICS			
Colour:	White	Body material:	Plastic
Finishing:	Matte	Body material tube:	Aluminium
Aesthetic:	ZENKAISUI	Color filter:	Dark red

PROGRAMME / FUNCTIONS			
Variable speed:	Yes	Speeds:	3 (min, max, auto)

CONTROLS			
Button ON/OFF:	Yes	Led Screen:	Yes

TECHNICAL FEATURES			
Typ of brush:	Motorized brush	Air inlet filter	HEPA stainless steel filter
Type of tube:	Aluminium	Dirty Tank	600ml
Accessories:	2	Cordless	Yes
Noise Level:	82 dB	Suction Power:	32Kpa, 120AW
Running Time:	Up to 80 minutes	Pet Care accessories:	No

ELECTRICAL CONNECTION			
Ultra fast Charging time:	Yes	Power:	500 W
Frequency:	29,6V~	Cordless:	Yes
Battery:	29,6V~ 3000mAh		

LOGISTIC INFORMATION			
Product length:	273 mm	Gross weight (kg):	3,6 kg
Product width:	255 mm	Net weight (kg):	3,3 kg
Product height:	1180 mm	Type of packaging:	Cartone
Width of the packed product:	295 mm	Carton box height:	30,3 cm
Depth of packaged product:	123 mm	Carton box dimensions:	688x131x303 mm
Height of the packed product:	679 mm	Master BOX	4