

# VACUUM CLEANER

## HOME CARE



## ZENKAISUI EVO 5

VACUUM CLEANER AVC-630

- **Battery Info:** 29.6V Li-ion, 8 domestic cells, 3AH
- **Noise Level:** 80 dB
- **Air Inlet Filter:** HEPA + stainless steel filter
- **Dust Tank Capacity:** 400ml
- **Accessories:** EB111 bristled nozzle with LED light, silver straight tube, H10HEPA, adapter, dust brush, crevice tool
- **Charger Wall Bracket:** YES
- **IA Zenkaisui Mode:** YES, Allows changing power device when not needed to improve working time
- **FLEX TUBE:** YES
- **Motorized Roller with LED Illumination:** YES
- **Digital Screen:** YES
- **Animal Kit:** YES
- **Ergonomic Handle:** YES
- **Motorized Roller with LED Illumination:** YES, for hard floors and carpet

### LIGHTWEIGHT POWERHOUSE

**Superior Suction:** Delivering 130AW suction and powered by a 500W motor, the Zenkaisui EVO 5 provides powerful cleaning performance, ideal for tackling stubborn dirt and debris.

**Efficient Filtration:** The HEPA and stainless steel filters ensure high air quality by capturing fine dust and allergens, making it suitable for allergy sufferers.

**Comprehensive Accessories:** The vacuum comes with a bristled nozzle with LED light, silver straight tube, H10HEPA filter, adapter, dust brush, and crevice tool, providing versatile cleaning solutions.

**User-Friendly Features:** The lightweight design (1.4 kg) and ergonomic handle make it easy to carry and maneuver, while the FLEX TUBE allows better access to dust and dirt in hard-to-reach areas.

**Digital Convenience:** The LED screen provides real-time information on battery life and cleaning modes, enhancing user experience.

Power	500 W Brushless motor (BLDC)
Suction	130 AW
Ultra fast Charging time	1,5h
IA Zenkaisui mode	Yes
Led Screen	Yes
Modes	4 (min, med, max, auto)
Running time	80 min

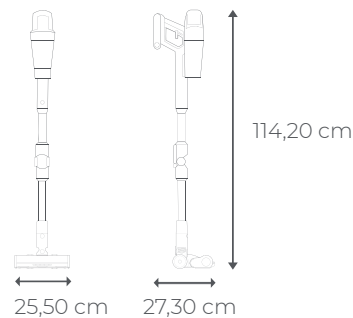

<b>500W</b>	<b>Cordless</b>	<b>80 minutes</b> Running Time	<b>4000 mAh</b> <b>29.6 V</b> Battery	<b>Ultra Fast Charging</b>	<b>0.4L</b> Dust Tank Capacity
<b>4</b> Presets	<b>80db</b>	<b>Hepa Filter</b>	<b>5</b> Accessories	<b>FLEX Tube</b>	

MODEL: AVC-630		
PRODUCT CODE	BAR CODE	MASTER BOX
9361004	8435256810561	2

# ZENKAISUI EVO 5

VACUUM CLEANER AVC-630

aiwa®

## SPECIFICATIONS

TYPE			
Category:	<b>HOME CARE</b>	Product Code:	<b>9316004</b>
Product Family:	<b>Cleaner</b>	EAN Code:	<b>8435256810561</b>
Type:	<b>Vacuum cleaner</b>	Motor power:	<b>500W</b>

AESTHETICS			
Colour:	<b>White</b>	Body material:	<b>Plastic</b>
Finishing:	<b>Matte</b>	Body material tube:	<b>Aluminium</b>
Aesthetic:	<b>ZENKAISUI</b>	Color filter:	<b>Dark red</b>

PROGRAMME / FUNCTIONS			
Variable speed:	<b>Yes</b>	Modes:	<b>4 (min, med, max, auto)</b>

CONTROLS			
Button ON/OFF:	<b>Yes</b>	Led Screen:	<b>Yes</b>

TECHNICAL FEATURES			
Typ of brush:	<b>Motorized brush</b>	Air inlet filter:	<b>HEPA stainless steel filter</b>
Type of tube:	<b>Aluminium</b>	Dust Tank:	<b>400ml</b>
Accessories:	<b>5</b>	Cordless:	<b>Yes</b>
Noise Level:	<b>≤80 dB</b>	Suction Power:	<b>32Kpa, 130AW</b>
Running Time:	<b>Up to 80 minutes</b>	Pet Care accessories:	<b>Yes</b>

ELECTRICAL CONNECTION			
Ultra fast Charging time	<b>Yes</b>	Power:	<b>500 W</b>
Frequency:	<b>29,6V~</b>	Cordless:	<b>Yes</b>
Battery	<b>29,6V~ 4000mAh</b>		

LOGISTIC INFORMATION			
Product length:	<b>273 mm</b>	Gross weight (kg):	<b>5,9 kg</b>
Product width:	<b>255 mm</b>	Net weight (kg):	<b>5,1 kg</b>
Product height:	<b>1142 mm</b>	Type of packaging:	<b>Cartone</b>
Width of the packed product:	<b>295 mm</b>	Carton box height:	<b>30,3 cm</b>
Depth of packaged product:	<b>123 mm</b>	Carton box dimensions:	<b>688x131x303 mm</b>
Height of the packed product:	<b>679 mm</b>	Master BOX	<b>4</b>