

# VACUUM CLEANER

## HOME CARE



### ZENKAISUI EVO 6

VACUUM CLEANER AVC-640

- **Battery Info:** 28,8 V@3000mAh, 8 cells
- **Noise Level:** 84 dB
- **Air Inlet Filter:** HEPA + stainless steel filter
- **Dust Tank Capacity:** 300ml
- **Accessories:** Nozzle with LED light, silver straight tube, H10HEPA filter, adapter, dust brush, crevice tool
- **Charging Base:** YES
- **Removable Battery Pack:** YES
- **IA Zenkaisui Mode:** Allows changing power device when not needed to improve working time
- **FLEX TUBE:** YES
- **Weight:** 2.5 kg
- **Motorized Roller with LED Illumination:** YES
- **Animal Kit:** YES
- **Ergonomic Handle:** YES
- **Multi-Stage Cyclone:** YES
- **Motorized Roller with LED Illumination:** YES, for hard floors and carpet

#### ZENKAISUI EVO 6: THE PEAK OF CLEAN

**Ergonomic Design:** With a weight of 2.5 kg and an ergonomic handle, the Zenkaisui EVO 6 is designed for comfort and ease of use, making it simple to maneuver around the home.

**Enhanced Control:** Featuring 5 cleaning modes (min, med, max, auto, turbo) and the intelligent IA Zenkaisui mode, it adapts to various cleaning needs, optimizing performance and efficiency.

**Innovative Technology:** The multi-stage cyclone system ensures 99.9% dust-air separation efficiency, while the LED screen provides real-time information on battery life and cleaning modes, enhancing the user experience.

**Japanese Precision:** Reflecting AIWA's commitment to quality and precision, the Zenkaisui EVO 6 combines cutting-edge technology with sleek design, offering exceptional performance and durability.

Power	550 W Brushless motor (BLDC)
Suction	200 AW
Noise Level (dB)	84
Ultra fast Charging time	1,5h
IA Zenkaisui mode	Yes
Speed	4 (min, med, max, turbo, auto)
Led Screen	Yes
Running time	68 min

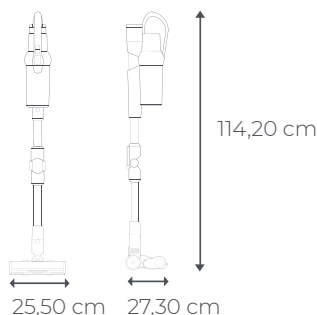

<b>550W</b>	<b>Cordless</b>	<b>68 minutes</b> Running Time	<b>3000 mAh</b> <b>28.8 V</b> Battery	<b>Ultra Fast Charging</b>	<b>0.3L</b> Dust Tank Capacity
<b>4</b> Speeds	<b>84db</b>	<b>Hepa Filter</b>	<b>5</b> Accessories	<b>FLEX Tube</b>	<b>Digital display</b>

MODEL: AVC-640		
PRODUCT CODE	BAR CODE	MASTER BOX
9361005	8435256810486	2

## SPECIFICATIONS

TYPE			
Category:	<b>HOME CARE</b>	Product Code:	<b>9316005</b>
Product Family:	<b>Cleaner</b>	EAN Code:	<b>8435256810554</b>
Type:	<b>Vacuum cleaner</b>	Motor power:	<b>550W</b>

AESTHETICS			
Colour:	<b>Dark gray</b>	Body material:	<b>Plastic</b>
Finishing:	<b>Matte</b>	Body material tube:	<b>Aluminium</b>
Aesthetic:	<b>ZENKAISUI</b>	Color filter:	<b>Black</b>

PROGRAMME / FUNCTIONS			
Variable speed:	<b>Yes</b>	Speeds:	<b>4 (min, med, max,turbo &amp; auto )</b>

CONTROLS			
Button ON/OFF:	<b>Yes</b>	Led Screen:	<b>Yes</b>

TECHNICAL FEATURES			
Typr of brush:	<b>Motoriezed brush</b>	Air inlet filter:	<b>HEPA stainless steel filter</b>
Type of tube:	<b>Aluminium</b>	Dust Tank:	<b>300ml</b>
Tube:	<b>Flex tube</b>	Cordless:	<b>Yes</b>
Accessories:	<b>5</b>	Charging base:	<b>Yes</b>
Noise Level:	<b>≤84 dB</b>	Suction Power:	<b>32Kpa, 200AW</b>
Running Time:	<b>Up to 80 minutes</b>	Pet Care accessories:	<b>Yes</b>

ELECTRICAL CONNECTION			
Ultra fast Charging time	<b>Yes</b>	Power:	<b>550 W</b>
Frequency:	<b>28.8V~</b>	Cordless	<b>Yes</b>
Battery	<b>28.8V~ 3000mAh</b>		

LOGISTIC INFORMATION			
Product lenght:	<b>273 mm</b>	Gross weight (kg):	<b>5,3 kg</b>
Product width:	<b>255 mm</b>	Net weight (kg):	<b>4,5 kg</b>
Product height:	<b>1142 mm</b>	Type of packaging:	<b>Cartone</b>
Widht of the packed product:	<b>347 mm</b>	Carton box height:	<b>35 cm</b>
Depth of packaged product:	<b>161 mm</b>	Carton box dimensions:	<b>785x365x350 mm</b>
Height of the packed product:	<b>770 mm</b>	Master BOX	<b>4</b>